



2025



beko

The Beko logo consists of the word "beko" in a bold, lowercase, sans-serif font. Below the text is a thick, white, slanted horizontal bar that starts under the 'b' and ends under the 'o', extending slightly beyond the 'o' on the right side.

FIDUCIA. È QUANDO SI FANNO LE SCELTE CORRETTE.
PER LE GIUSTE RAGIONI.

A CASA. COSÌ COME NELLA VITA.

IN QUALSIASI SITUAZIONE TU POSSA TROVARTI,

CON BEKO FAI UNA SCELTA DI VITA.

È UN SENTIMENTO.

QUALSIASI COSA LA VITA TI RISERVI, **NOI SIAMO AL TUO**

FIANCO. CON LE SOLUZIONI DI CUI HAI BISOGNO.

PER GUIDARTI VERSO **UNO STILE DI VITA PIÙ SANO.**

RIDUCENDO IL CONSUMO DI ENERGIA IN CASA.

SEMPLIFICANDOTI LA VITA,

CON PRODOTTI SU CUI CONTARE, ELIMINANDO OGNI FONTE
DI STRESS.

SEI TU A SCEGLIERE.

È UN'ATTITUDINE.

LA FIDUCIA CHE RIPONI IN NOI È UNO STIMOLO PER ESSERE

SEMPRE PIÙ AFFIDABILI.

PIÙ FIDUCIA CI DAI,

PIÙ DIVENTIAMO UN BRAND DI RIFERIMENTO IN GRADO

DI OTTENERE RICONOSCIMENTI IMPORTANTI.

ABBIAMO DATO FORMA ALLA NOSTRA VISIONE

CON PASSIONE, DEDIZIONE E SERENITÀ.

CON GRANDE FIDUCIA.

BEKO, UNA SCELTA DI VITA.

beko

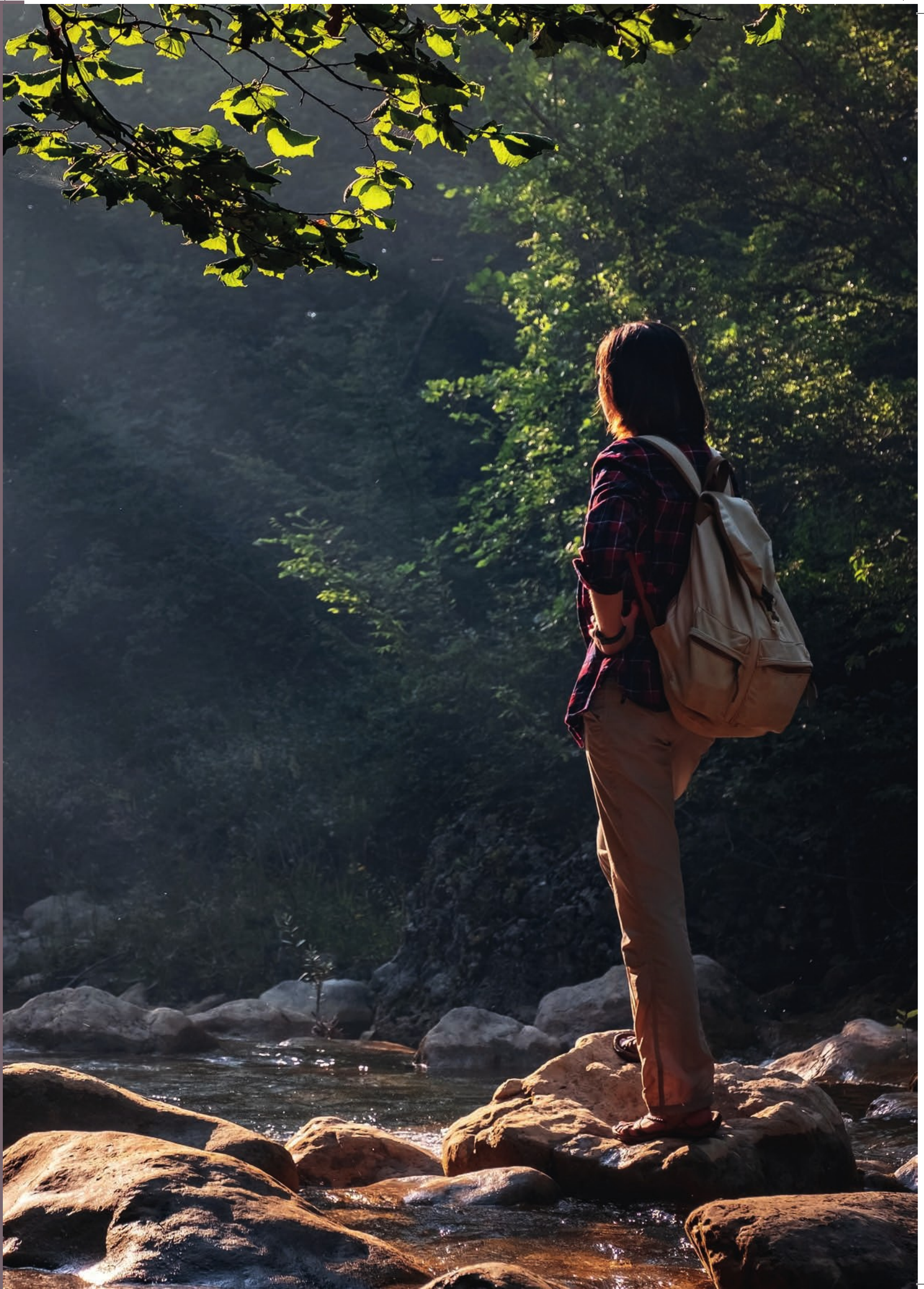

COLLEZIONE MIDNIGHT

Beko presenta la nuova ed esclusiva collezione da incasso, **Midnight Line**: una linea estetica distintiva che sposa le ultime tendenze di design che si stanno affermando nell'ambito dell'arredo.

Fil rouge della collezione i toni scuri tendenti al "notte" sullo spettro dei pantoni del grigio e dell'antracite, finiture opache e satinare che creano un effetto unico e naturale e con un dettaglio tocco chic retrò della maniglia che fa da contrasto con la linearità del design più moderno: questi i key assets che determinano la cifra stilistica di Midnight.



Le tonalità grigio scuro e la finitura prevalente "matt" che donano una sensazione di morbidezza e confort al tatto, così come i sapienti abbinamenti dei materiali frutto di una selezione accurata creano un "continuum" tra gli elementi della collezione e una perfetta armonia con l'ambiente circostante.

È Il forno il prodotto che racchiude l'essenza estetica della gamma, si distingue con un elemento iconico: la maniglia modern-retrò che conferisce al prodotto e all'intero set una personalità unica, destinata a durare nel tempo.

Scansiona
e scopri



01

**LA COLLEZIONE
MIDNIGHT SI
COMPONE DI
FORNO, PIANO
COTTURA A
INDUZIONE.**



MIDNIGHT LINE SI È AGGIUDICATA A FEBBRAIO 2024, **IF DESIGN AWARD**, UNO DEI PIÙ PRESTIGIOSI RICONOSCIMENTI INTERNAZIONALI NEL CAMPO DEL DESIGN ASSEGNATO DA IF INTERNATIONAL FORUM DESIGN GMBH.



L'ORGANISMO INDIPENDENTE DI DESIGN PIÙ ANTICO
AL MONDO CON SEDE AD HANNOVER, TESTIMONIANZA
DELLA VOCAZIONE DELL'AZIENDA NEL PROGETTARE
SOLUZIONI TECNOLOGICHE ALL'AVANGUARDIA IN CUI
L'INNOVAZIONE SI SPOSA CON L'ESTETICA.



**SONO LE NOSTRE SCELTE
A DETERMINARE IL
NOSTRO STILE DI VITA.
PIÙ SONO CORRETTE,
PIÙ VIVIAMO IN MODO
SANO E CONTRIBUIAMO
A CREARE UN MONDO
PIÙ VERO.**

A person in a blue jacket and light-colored pants stands on a dark, rocky path on the left side of the image, looking out over a vast, green, hilly landscape. The hills are covered in lush green grass and are bathed in the warm, golden light of the sun, which is low in the sky, creating long shadows and a soft glow. The terrain is rugged, with deep gullies and rocky outcrops. In the distance, a few small white structures are visible on a hillside. The overall atmosphere is serene and majestic.

BEKO È DA SEMPRE PARTE
ATTIVA DI QUESTO CIRCOLO
VIRTUOSO. PROGETTARE
TECNOLOGIE INNOVATIVE
E SOSTENIBILI È SOLO UNA
PARTE DEL NOSTRO IMPEGNO
PER LA SALVAGUARDIA DEL
PIANETA. NOI DI BEKO SIAMO IN
PRIMA LINEA ANCHE QUANDO
SI TRATTA DI FARE CULTURA
E INFORMAZIONE PER
SENSIBILIZZARE E ISPIRARE IL
PIÙ AMPIO PUBBLICO POSSIBILE
A INTRAPRENDERE SCELTE
CONSAPEVOLI E RESPONSABILI
A FAVORE DEL PIANETA.

BEKO, UNA SCELTA DI VITA.



5 ANNI DI ASSISTENZA

Gli elettrodomestici da incasso Beko presenti in questo catalogo* beneficiano di ben tre anni di assistenza supplementare oltre ai due anni di garanzia convenzionale.

Un servizio offerto gratuitamente da Beko ai propri clienti fino al 31 Dicembre 2025, registrando i prodotti entro 30 giorni dall'acquisto o dalla consegna.

*ad eccezione dei prodotti di seguito elencati:

**BBIC14000X - BBIC11000B - HIGG641C3SX -
BDIN25320 - BDSA250K4SN - BDSA250K4SNLH**

**01 COLLEZIONE
MIDNIGHT 04**

02 FORNI 12

Midnight	13
DeepBlack™	16
Dark Inox	24
Nature	26
Shine	32
Look	38
Rustic	40
Basic	42
Compatto & scaldavivande	44
Microonde	46

**03 PIANI COTTURA
& CAPPE 52**

Midnight	54
Piani a Induzione con cappa integrata	56
Piani a Induzione	62
Piani a Gas	72

04 LAVASTOVIGLIE 90

**05 FRIGORIFERI &
CONGELATORI 100**

**06 LAVATRICI &
LAVASCIUGA 122**







INDICE

LINEA ESTETICA MIDNIGHT

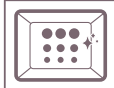
Una linea estetica distintiva che sposa le ultime tendenze di design, che si stanno affermando nell'ambito dell'arredo.

Le tonalità grigio scuro e la finitura prevalente "matt" donano una sensazione di morbidezza e confort al tatto, così come i sapienti abbinamenti dei materiali frutto di una selezione accurata creano un "continuum" tra gli elementi della collezione e una perfetta armonia con l'ambiente circostante.



	NUMERO DI FUNZIONI	15	15	13
 COTTURA A VAPORE STEAMAID™		■	-	-
 PULIZIA PIROLITICA		-	■	-
 TIPOLOGIA DI PULIZIA A VAPORE		SteamShine	HidroClean	HidroClean
 AIRFRY		-	■	-
 SOFTCLOS®		■	■	■
 PARETI CATALITICHE		■	-	■
 Wi-Fi HomeWhiz ®		■	■	■



MBBIS10600MTMSE

Forno **Multifunzione assistito a vapore SteamAid™**

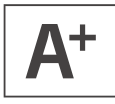

MBBIMA10600MTPSWE

Forno **Multifunzione Pirolitico AirFry**

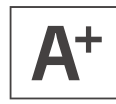

AeroPerfect®



Cottura assistita a vapore SteamAid™



SmartBake PRO



Pulizia a vapore SteamShine



Pareti catalitiche



Connettività Wi-Fi HomeWhiz®



SoftClose®



Guida telescopica



AeroPerfect®



AirFry

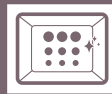

Pulizia Pirolitica



Pulizia a vapore HidroClean



Connettività Wi-Fi HomeWhiz®



SoftClose®



Guida telescopica

CARATTERISTICHE PRINCIPALI

- bPRO500
- Display Intuitive touch
- Volume cavità 72 L
- Cristallo nero matte
- 3 vetri controporta
- Rastrelliere laterali smontabili a 5 livelli

Cod. LUBE
0 7 2 4 6 0 Q 1 L

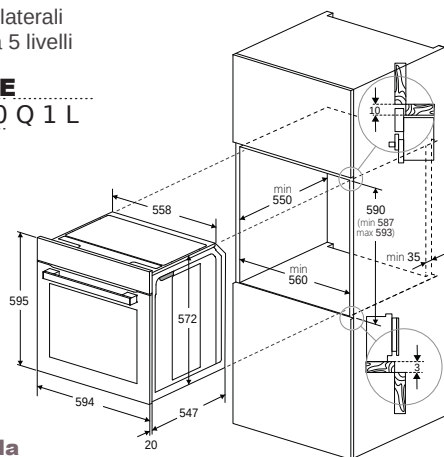

Disponibile da
Marzo 2025

CODICE SAP
7757883842

CODICE EAN
8690842637865

CARATTERISTICHE PRINCIPALI

- bPRO500
- Display Intuitive touch
- Volume cavità 72 L
- Cristallo nero matte
- 3 vetri controporta
- Rastrelliere laterali smontabili a 5 livelli

Cod. LUBE
0 7 2 4 6 0 Q 1 M

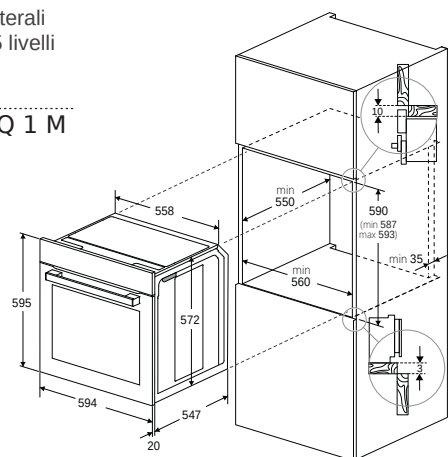

Disponibile da
Marzo 2025

CODICE SAP
7754886766

CODICE EAN
8690842730115

MBBIM10600MTMSWForno **Multifunzione**

AeroPerfect®

Pulizia a vapore
HydroClean

Pareti catalitiche

Connettività Wi-Fi
HomeWhiz®

SoftClose®

Guida
telescopica**CARATTERISTICHE PRINCIPALI**

- bPRO500
- Display Intuitive touch
- Volume cavità 72 L
- Cristallo nero matte
- 3 vetri controporta
- Rastrelliere laterali smontabili a 5 livelli

Cod. LUBE

0 7 2 4 6 0 Q 1 N

FUNZIONI DI COTTURA

- 13 funzioni di cottura
- Funzione pizza
- Resistenza circolare su ventola

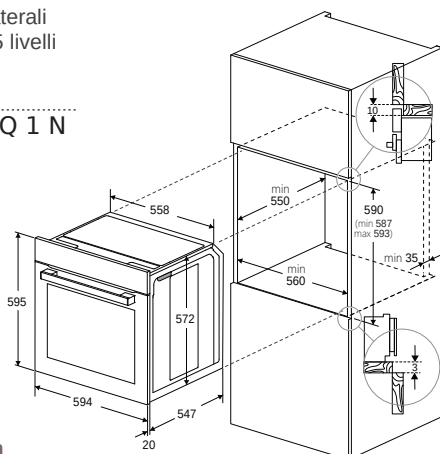
Disponibile da
Marzo 2025CODICE SAP
7768382120CODICE EAN
8690842637834

LINEA DEEPBLACK™

IL **DESIGN TOTAL BLACK** CREA
UN **FORTE IMPATTO VISIVO**,
PER ATTIRARE L'ATTENZIONE E COMUNICARE
UN SENSO DI **RAFFINATEZZA E VERSALITÀ**.







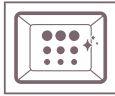

LINEA ESTETICA **DEEPBLACK™**

Lo stile futuristico è esaltato da un design total black. Il vetro a specchio crea profondità aggiungendo un aspetto sofisticato e raffinato, che si abbina perfettamente a mobili scuri minimal-chic e ad uno stile di vita tecnologico.



	NUMERO DI FUNZIONI	20	13
	COTTURA A VAPORE STEAMAID™	■	-
	COTTURA A VAPORE STEAMASSIS®	-	-
	PULIZIA PIROLITICA	■	-
	TIPOLOGIA DI PULIZIA A VAPORE	SteamShine	HidroClean
	AIRFRY	■	■
	SOFTCLOS®	■	■
	WIFI HomeWhiz®	-	-

b300

BCBIS17300KSBCS



BCBIM17300KSB



BCBIE17300KSB



9

9

6

-

-

-



-

-

-

-

-

HidroClean

HidroClean

HidroClean



-

-



-

-

-

-

BCBISA17400KSBMPS

Forno Multifunzione Pirolitico AirFry
assistito a vapore **SteamAid™**



BCBIMA17400KSBS

Forno Multifunzione AirFry



AeroPerfect®



Vapore
SteamAid™



Funzione
AirFry



Pulizia Pirolitica



Pulizia a vapore
SteamShine



SoftClose®



Guida
telescopica



AeroPerfect®



Funzione
AirFry



Pulizia a vapore
HydroClean



SoftClose®



Guida
telescopica

CARATTERISTICHE PRINCIPALI

- bPRO500
- Display LED Direct Access Touch
- Volume cavità 72 L
- Cristallo nero
- 4 vetri controporta
- Rastrelliere laterali smontabili a 5 livelli
- Sonda carne

Cod. LUBE
072460Q2B

FUNZIONI DI COTTURA

- 20 funzioni di cottura
- Funzione pizza
- Resistenza circolare su ventola
- Funzioni speciali combinate con vapore

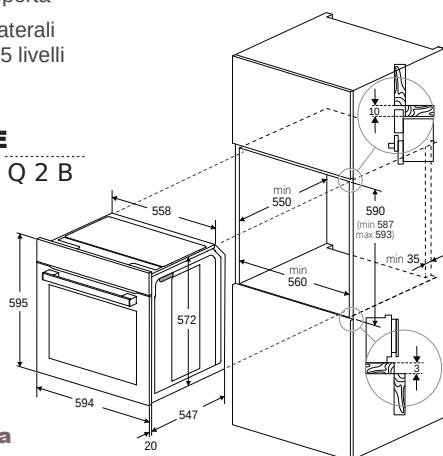

Disponibile da
Marzo 2025

CODICE SAP
7729486414

CODICE EAN
8690842696978

CARATTERISTICHE PRINCIPALI

- bPRO500
- Display LED Direct Access Touch
- Volume cavità 72 L
- Cristallo nero
- 3 vetri controporta
- Rastrelliere laterali smontabili a 5 livelli

Cod. LUBE
072460Q2C

FUNZIONI DI COTTURA

- 13 funzioni di cottura
- Funzione pizza
- Resistenza circolare su ventola

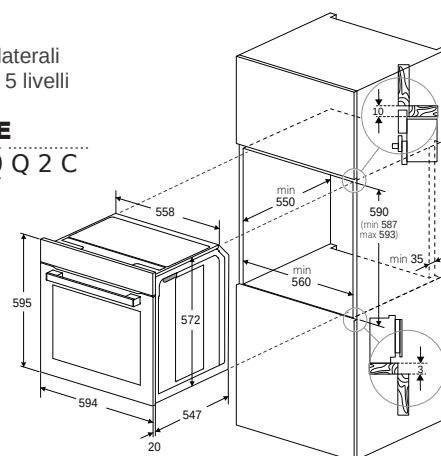

CODICE SAP
7729486417

CODICE EAN
8690842696992



BCRIS17300KSBMPS

Forno **Multifunzione AirFry**
assistito a vapore **SteamAssist®**



BCBIM17300KSB

Forno **Multifunzione**



AeroPerfect®



Vapore
SteamAssist®



Funzione
AirFry



Pulizia a vapore
HydroClean



SoftClose®



2 x Guida
telescopica



AeroPerfect®



Pulizia a vapore
HydroClean



SoftClose®



Guida
telescopica

CARATTERISTICHE PRINCIPALI

- b300
- Display LED con manopole
- Volume cavità 72 L
- Cristallo nero
- 3 vetri controporta
- Rastrelliere laterali smontabili a 5 livelli

Cod. LUBE

0 7 2 4 6 0 Q 2 D

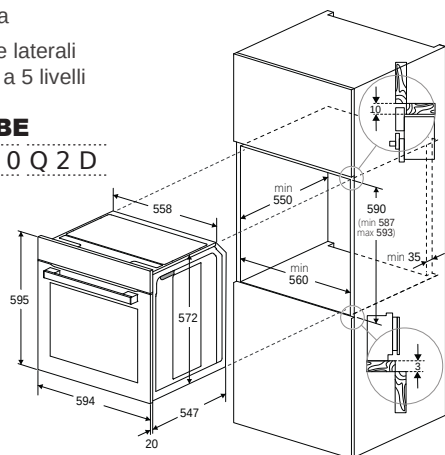

FUNZIONI DI COTTURA

- 9 funzioni di cottura
- Funzione pizza
- Resistenza circolare su ventola

CARATTERISTICHE PRINCIPALI

- b300
- Display LED con manopole
- Volume cavità 72 L
- Cristallo nero
- 3 vetri controporta
- Rastrelliere laterali smontabili a 5 livelli

Cod. LUBE

0 7 2 4 6 0 Q 2 E

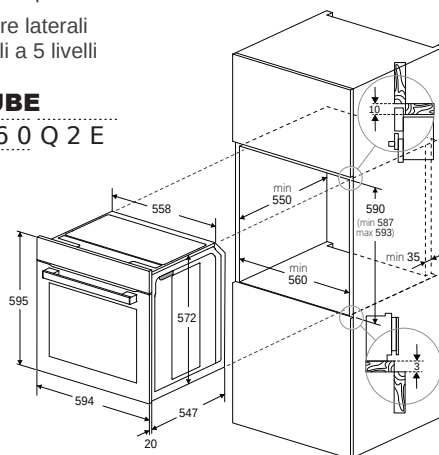

FUNZIONI DI COTTURA

- 9 funzioni di cottura
- Funzione pizza
- Resistenza circolare su ventola

CODICE SAP
7729486416

CODICE EAN
8690842696862

CODICE SAP
7729486411

CODICE EAN
8690842696855

BCBIE17300KSB

Forno Multifunzione



AeroPerfect®



Pulizia a vapore
HydroClean



Guida
telescopica

CARATTERISTICHE PRINCIPALI

- b300
- Display LED con manopole
- Volume cavità 72 L
- Cristallo nero
- 3 vetri controporta
- Rastrelliere laterali smontabili a 5 livelli

FUNZIONI DI COTTURA

- 6 funzioni di cottura

Cod. LUBE

0 7 2 4 6 0 Q 2 F

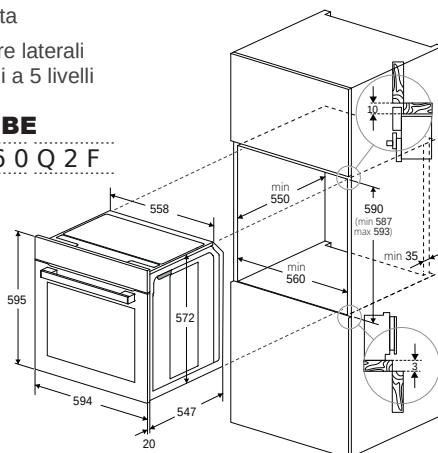

CODICE SAP
7768288337

CODICE EAN
8690842645020



LINEA ESTETICA **DARK INOX**

Una espressione moderna e senza tempo valorizzata dalla maniglia del forno e dalle finiture in acciaio inox scuro. Il nuovo colore acciaio inox satinato dona un aspetto contemporaneo, abbinandosi perfettamente alla texture metallica e alle finiture scure.



	bPRO500 BBIM13400DXMPSE	b300 BBIM13300CDXE
NUMERO DI FUNZIONI	15	9
PULIZIA PIROLITICA	■	-
TIPOLOGIA DI PULIZIA A VAPORE	HydroClean	HydroClean
SOFTCLOS®	■	-
PARETI CATALITICHE	-	■
GUIDE TELESCOPICHE	■	■

BBIM1340DXMPSE

Forno Multifunzione Pirolitico



BBIM1330CDXE

Forno Multifunzione

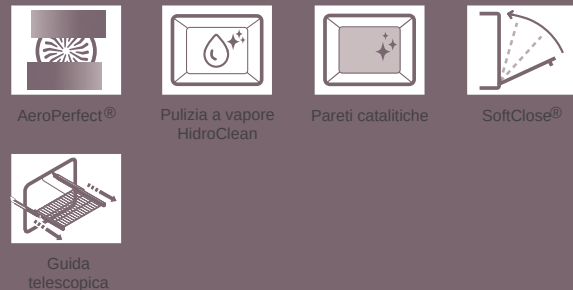
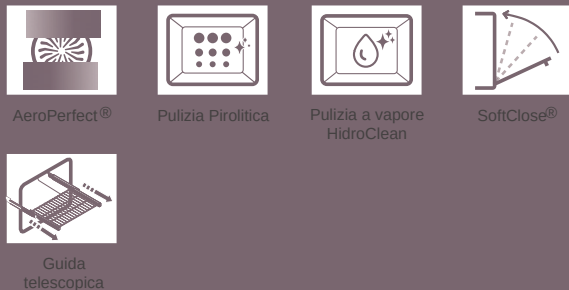

CARATTERISTICHE PRINCIPALI

- bPRO500
- Display LED Direct Access Touch con manopola centrale
- Volume cavità 72 L
- Cristallo nero e acciaio dark inox
- 4 vetri controporta
- Rastrelliere laterali smontabili a 5 livelli

Cod. LUBE
072460Q1E

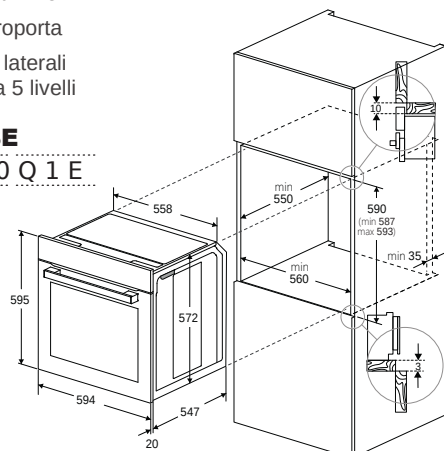

FUNZIONI DI COTTURA

- 15 funzioni di cottura
- Funzione pizza
- Resistenza circolare su ventola

CARATTERISTICHE PRINCIPALI

- b300
- Display LED con manopole
- Volume cavità 72 L
- Cristallo nero
- 2 vetri controporta
- Rastrelliere laterali smontabili a 5 livelli

Cod. LUBE
072460Q1F

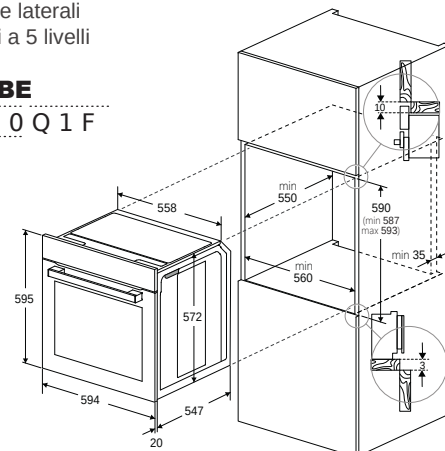

FUNZIONI DI COTTURA

- 9 funzioni di cottura
- Funzione pizza
- Resistenza circolare su ventola

CODICE SAP
7757787668

CODICE EAN
8690842619243

CODICE SAP
7768286734

CODICE EAN
8690842453397

LINEA ESTETICA **NATURE**

Linee pulite e forme funzionali che si adattano ad ogni stile di arredamento.
Integrazione di tecnologie moderne che rende ogni cottura efficiente.



	bPRO700	bPRO500	
	BBIM13500XPSW	BBIS13400XMSWA	EBBVM13400XDS
NUMERO DI FUNZIONI	15	15	14
SPLIT&COOK®	-	-	■
COTTURA A VAPORE STEAMAID™	-	■	-
COTTURA A VAPORE STEAMASSIS®	-	-	-
PULIZIA PIROLITICA	■	-	-
TIPOLOGIA DI PULIZIA A VAPORE	HidroClean	SteamShine	HidroClean
AIRFRY	-	-	-
SOFTCLOS®	■	■	■
WIFI HomeWhiz®	■	■	-

b300				b100
BBIS13300XMSE	BBIMA13300XS	BBIE13301XMP	BBIM13300X	BBIE13100X
				
9	9	9	8	6
-	-	-	-	-
-	-	-	-	-
■	-	-	-	-
-	-	■	-	-
HidroClean	HidroClean	HidroClean	HidroClean	HidroClean
-	■	-	-	-
■	■	-	-	-
-	-	-	-	-

BBIM13500PSW

Forno **Multifunzione Pirolitico**
con **80 ricette automatiche**



BBIS13400XMSWAE

Forno **Multifunzione assistito**
a vapore **SteamAid™** in **Classe A++**



AeroPerfect®



Pulizia Pirolitica



Pulizia a vapore
HydroClean



Connettività Wi-Fi
HomeWhiz®



AeroPerfect®



Vapore
SteamAid™



SmartBake PRO



Pulizia a vapore
SteamShine



SoftOpen



SoftClose®



2 x Guide
telescopiche



Pareti
catalitiche



Connettività Wi-Fi
HomeWhiz®



SoftClose®



Guida
telescopica

CARATTERISTICHE PRINCIPALI

- bPRO700
- Display TFT 2,4" con manopola centrale
- Volume cavità 71 L
- Cristallo nero e acciaio inox
- 4 vetri controporta
- Rastrelliere laterali smontabili a 5 livelli
- Sonda carne

Cod. LUBE

0 7 2 4 6 0 Q 5 F

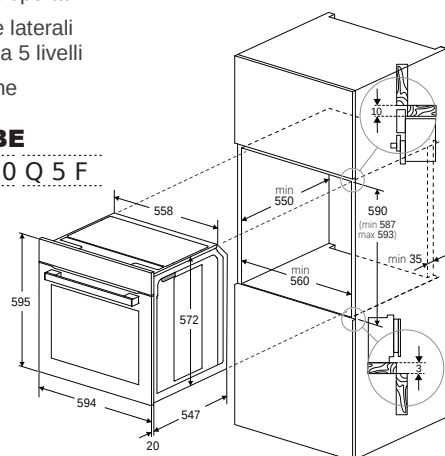

FUNZIONI DI COTTURA

- 15 funzioni di cottura
- 80 ricette automatiche
- Funzione pizza
- Resistenza circolare su ventola

CARATTERISTICHE PRINCIPALI

- bPRO500
- Display LED Direct Access Touch con manopola centrale
- Volume cavità 72 L
- Cristallo nero e acciaio inox
- 3 vetri controporta
- Rastrelliere laterali smontabili a 5 livelli

Cod. LUBE

0 7 2 4 6 0 Q 5 G

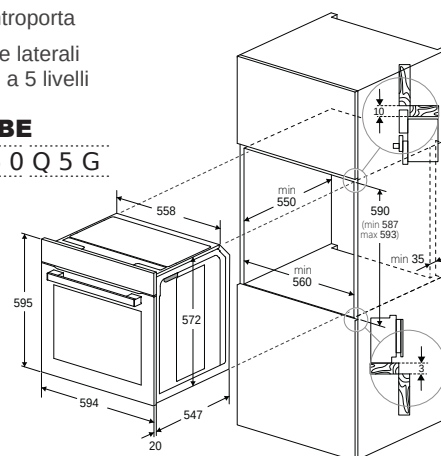

FUNZIONI DI COTTURA

- 15 funzioni di cottura
- Funzione pizza
- Resistenza circolare su ventola

CODICE SAP
7757788409

CODICE EAN
8690842453304

CODICE SAP
7768287824

CODICE EAN
8690842508943

BBVM13400XDS

Forno **Multifunzione Split&Cook**



CARATTERISTICHE PRINCIPALI

- bPRO500
- Display LED Direct Access con manopole
- Volume cavità 72 L (cavità superiore 35 L ed inferiore 34 L)
- Cristallo nero e acciaio inox
- 3 vetri controporta
- Rastrelliere laterali smontabili a 5 livelli

Cod. LUBE
072460Q5E

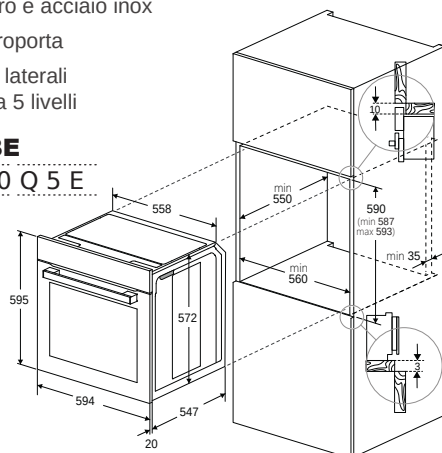

CODICE SAP
7768287623

CODICE EAN
8690842495151

BBIS13300XMSE

Forno **Multifunzione assistito a vapore SteamAssist**

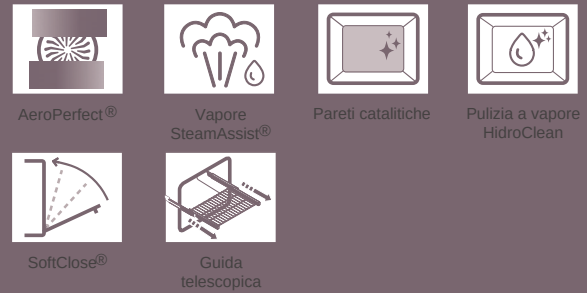

CARATTERISTICHE PRINCIPALI

- b300
- Display LED con manopole
- Volume cavità 72 L
- Cristallo nero e acciaio inox
- 2 vetri controporta
- Rastrelliere laterali smontabili a 5 livelli

Cod. LUBE
072460Q5C

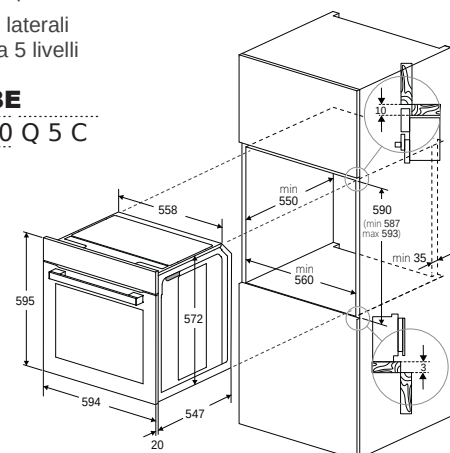

CODICE SAP
7724086710

CODICE EAN
8690842295379

BBIMA13300XS

Forno Multifunzione AirFry



BBIE13301XMP

Forno Multifunzione Piroolitico



AeroPerfect®



AirFry



Pareti catalitiche



Pulizia a vapore
HydroClean



SoftClose®



Guida
telescopica



AeroPerfect®



Pulizia Pirolitica



Pulizia a vapore
HydroClean

CARATTERISTICHE PRINCIPALI

- b300
- Display LED con manopole
- Volume cavità 72 L
- Cristallo nero e acciaio inox
- 3 vetri controporta
- Rastrelliere laterali smontabili a 5 livelli

Cod. LUBE
072460Q1H

FUNZIONI DI COTTURA

- 9 funzioni di cottura
- Funzione pizza
- Resistenza circolare su ventola

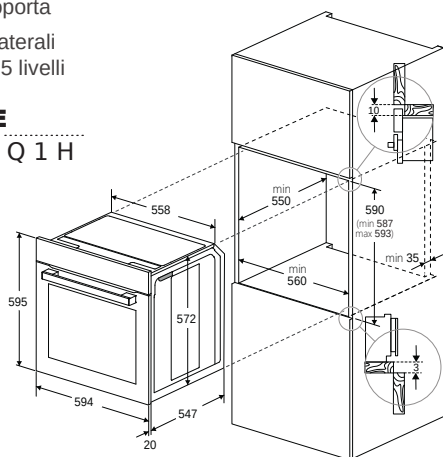

CARATTERISTICHE PRINCIPALI

- b300
- Display LED con manopole
- Volume cavità 66 L
- Cristallo nero e acciaio inox
- 4 vetri controporta

Cod. LUBE
072460Q5B

FUNZIONI DI COTTURA

- 9 funzioni di cottura

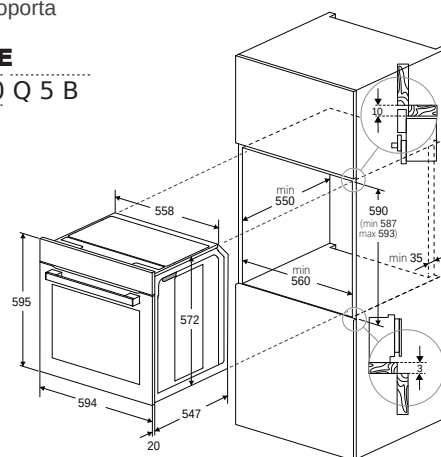

CODICE SAP 7779420235 | **CODICE EAN** 8690842567759

CODICE SAP 7757787686 | **CODICE EAN** 8690842570582

BBIM13300X

Forno **Multifunzione**



AeroPerfect®



Pulizia a vapore
HydroClean

CARATTERISTICHE PRINCIPALI

- b300
- Display LED con manopole a scomparsa
- Volume cavità 72 L
- Cristallo nero e acciaio inox
- 3 vetri controporta
- Rastrelliere laterali smontabili a 5 livelli

Cod. LUBE
072460Q5H

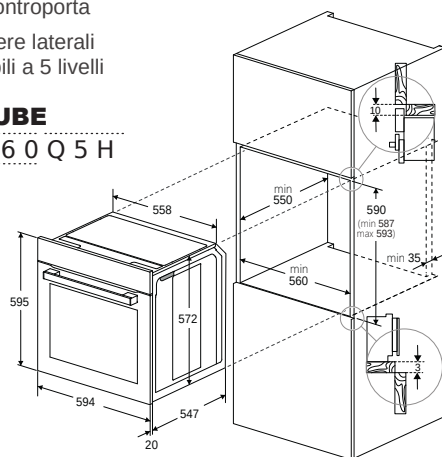

CODICE SAP
7768282917

CODICE EAN
8690842403330

BBIE13100X

Forno **Multifunzione**



AeroPerfect®



Pulizia a vapore
HydroClean

CARATTERISTICHE PRINCIPALI

- b100
- 3 manopole meccaniche
- Volume cavità 72 L
- Cristallo nero e acciaio inox
- 2 vetri controporta
- Rastrelliere laterali smontabili a 5 livelli

Cod. LUBE
072460Q5A

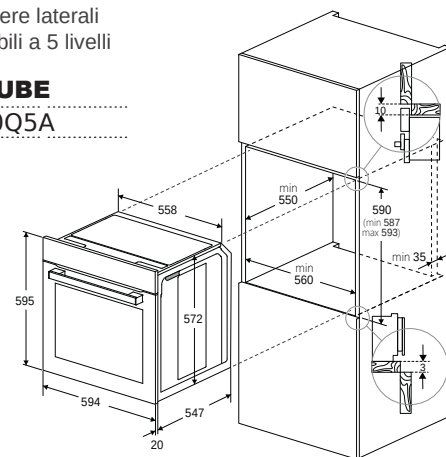







CODICE SAP
7757883880

CODICE EAN
8690842523106

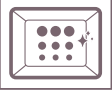
LINEA ESTETICA SHINE

L'armonia e la solidità dell'acciaio si fondono per conquistare le diverse modalità di cottura. Le funzioni si adattano alle varie esigenze culinarie, anche le più tradizionali.



	NUMERO DI FUNZIONI	13	8	9
	COTTURA A VAPORE STEAMASSIS®	-	-	■
	PULIZIA PIROLITICA	-	-	-
	TIPOLOGIA DI PULIZIA A VAPORE	HydroClean	HydroClean	HydroClean
	AIRFRY	-	-	-
	SOFTCLOS®	■	■	-
	PARETI CATALITICHE	-	-	-
	WIFI HomeWhiz®	■	-	-



9	9	8	6
-	-	-	-
■	-	-	-
HidroClean	HidroClean	HidroClean	HidroClean
-	■	-	-
-	-	-	-
-	■	-	-
-	-	-	-

BBIM1440XSWE

Forno **Multifunzione**



AeroPerfect®



Pulizia a vapore
HidroClean



Connettività Wi-Fi
HomeWhiz®



SoftClose®



Guida
telescopica

CARATTERISTICHE PRINCIPALI

- bPRO500
- Display LED Direct Access Touch con manopola centrale
- Volume cavità 72 L
- Finitura acciaio inox
- 3 vetri controporta
- Rastrelliere laterali smontabili a 5 livelli

Cod. LUBE
0 7 2 4 6 0 Q 2 Z

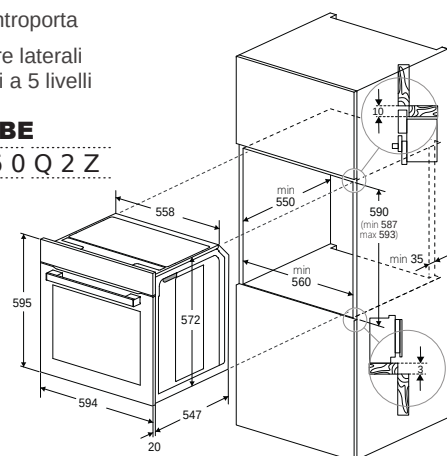

CODICE SAP
7757883881

CODICE EAN
8690842523076

BBWM12300X

Forno **Multifunzione**
da **90 cm**



AeroPerfect®



Pulizia a vapore
HidroClean



SoftClose®

CARATTERISTICHE PRINCIPALI

- b300
- Display LED con manopole
- Volume cavità 111 L
- Finitura acciaio inox
- 3 vetri controporta
- Rastrelliere laterali smontabili a 5 livelli

Cod. LUBE
0 7 2 4 8 9 Q 9 2

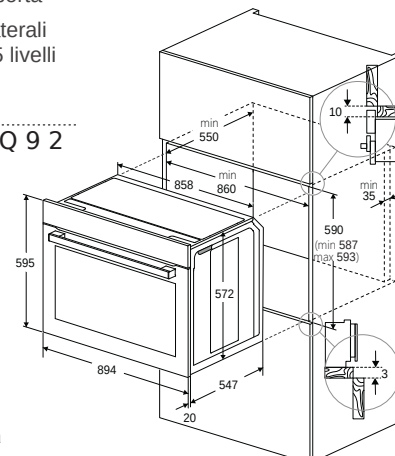

Disponibile da
Marzo 2025

CODICE SAP
9151111005

CODICE EAN
6221378000650

BBIS14300XE

Forno **Multifunzione assistito a vapore SteamAssist**



AeroPerfect®



Vapore SteamAssist®



Pulizia a vapore HydroClean



Guida telescopica

CARATTERISTICHE PRINCIPALI

- b300
- Display LED con manopole
- Volume cavità 72 L
- Finitura acciaio inox
- 2 vetri controporta
- Rastrelliere laterali smontabili a 5 livelli

Cod. LUBE
072460Q2Y

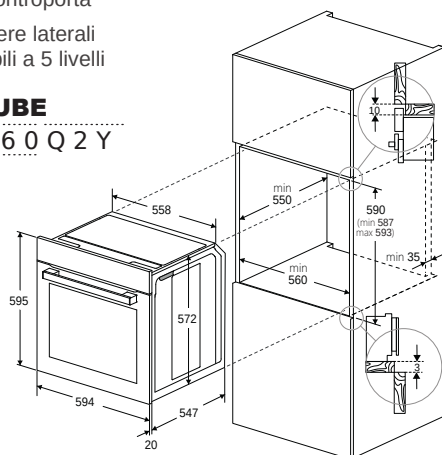

CODICE SAP
7757883879

CODICE EAN
8690842535864

BBIE12301XMP

Forno **Multifunzione Piroolitico**



AeroPerfect®



Pulizia Pirolitica



Pulizia a vapore HydroClean

CARATTERISTICHE PRINCIPALI

- b300
- Display LED con manopole
- Volume cavità 72 L
- Finitura acciaio inox
- 4 vetri controporta
- Rastrelliere laterali smontabili a 5 livelli

Cod. LUBE
072460Q2X

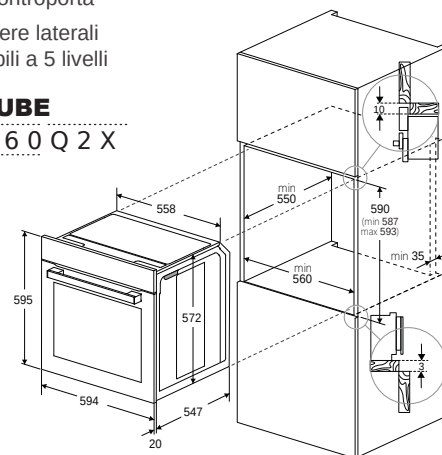

CODICE SAP
7724086785

CODICE EAN
8690842603938

BBIMA12300X

Forno **Multifunzione AirFry**



BBIM12300X

Forno **Multifunzione**



AeroPerfect®



AirFry



Pareti catalitiche



Pulizia a vapore
HydroClean



AeroPerfect®



Pulizia a vapore
HydroClean

CARATTERISTICHE PRINCIPALI

- b300
- Display LED con manopole
- Volume cavità 72 L
- Finitura acciaio inox
- 2 vetri controporta
- Rastrelliere laterali smontabili a 5 livelli

Cod. LUBE
072460Q2V

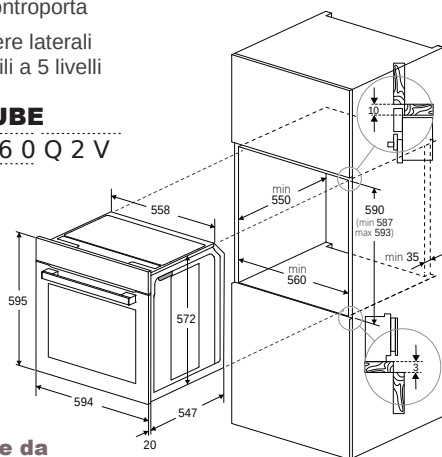

Disponibile da
Marzo 2025

CODICE SAP
7754886765

CODICE EAN
8690842733130

CARATTERISTICHE PRINCIPALI

- b300
- Display LED con manopole
- Volume cavità 72 L
- Finitura acciaio inox
- 2 vetri controporta
- Rastrelliere laterali smontabili a 5 livelli

Cod. LUBE
072460Q24

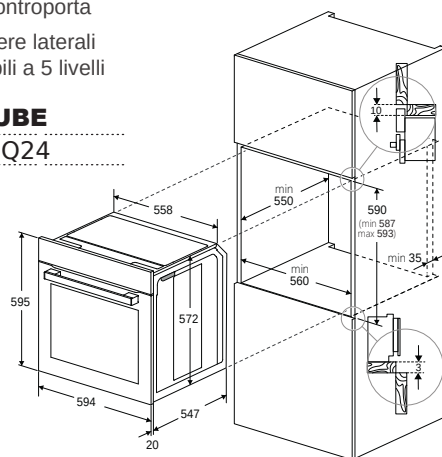

CODICE SAP
7757883864

CODICE EAN
8690842522956

BBIE12100XForno **Multifunzione**

AeroPerfect®

Pulizia a vapore
HydroClean**CARATTERISTICHE PRINCIPALI**

- b100
- 3 manopole meccaniche
- Volume cavità 72 L
- Finitura acciaio inox
- 2 vetri controporta
- Rastrelliere laterali smontabili a 5 livelli

Cod. LUBE

072460Q15

FUNZIONI DI COTTURA

- 6 funzioni di cottura

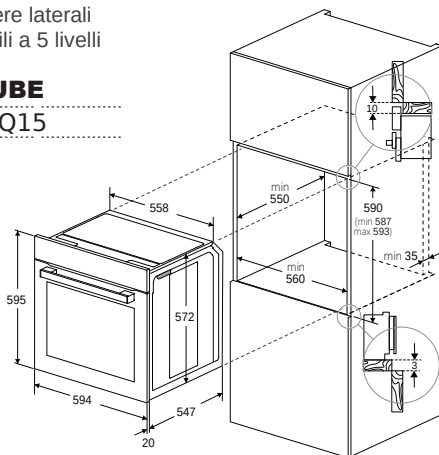
CODICE SAP
7757883863

CODICE EAN
8690842522932

LINEA ESTETICA **LOOK**

La linea estetica per un colore e un look da sperimentare per creare un ambiente personalizzato e luminoso dal risultato unico.



BBIM13300ZGCSE

Forno Multifunzione



AeroPerfect®



Pareti catalitiche



Pulizia a vapore
HidroClean



SoftClose®



Guida
telescopica

CARATTERISTICHE PRINCIPALI

- b300
- Display LED con manopola a scomparsa
- Volume cavità 72 L
- Cristallo zara grey e acciaio inox
- 2 vetri controporta
- Rastrelliere laterali smontabili a 5 livelli

Cod. LUBE
072460Q1B

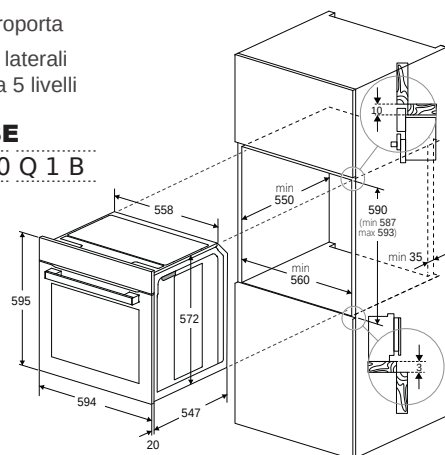

CODICE SAP
7751788324

CODICE EAN
8690842422768

BBIM14300WMS

Forno Multifunzione



AeroPerfect®



Pulizia a vapore
HidroClean



SoftClose®



Guida
telescopica

CARATTERISTICHE PRINCIPALI

- b300
- Display LED con manopola a scomparsa
- Volume cavità 72 L
- Cristallo bianco e acciaio inox
- 2 vetri controporta
- Rastrelliere laterali smontabili a 5 livelli

Cod. LUBE
072460Q1A

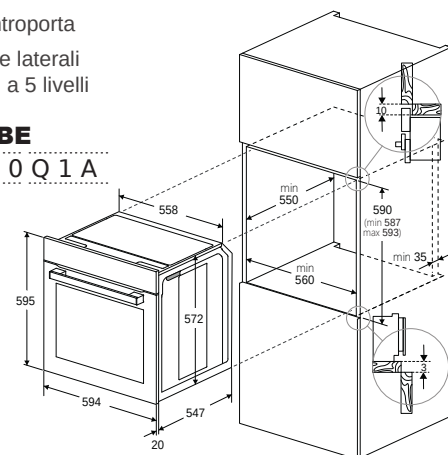

CODICE SAP
7768182103

CODICE EAN
8690842396458

LINEA ESTETICA **RUSTIC**

Un design che richiama la tradizione, fulcro di momenti conviviali e di socializzazione.

L'elemento centrale distintivo è l'idea di calore domestico e ambiente familiare.



RBIM19200AD

Forno **Multifunzione**



RBIM19200AVD

Forno **Multifunzione**



AeroPerfect®



Pulizia a vapore
HydroClean



AeroPerfect®



Pulizia a vapore
HydroClean

CARATTERISTICHE PRINCIPALI

- b300
- Programmazione meccanica con orologio
- Volume cavità 72 L
- Finitura colore antracite
- 3 vetri controporta
- Rastrelliere laterali smontabili a 5 livelli

Cod. LUBE
072560Q44

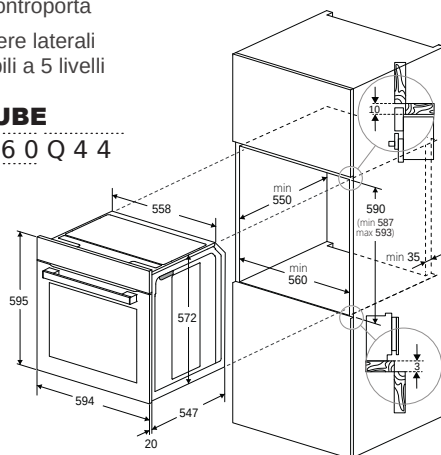

FUNZIONI DI COTTURA

- 8 funzioni di cottura
- Resistenza circolare su ventola

CARATTERISTICHE PRINCIPALI

- b300
- Programmazione meccanica con orologio
- Volume cavità 72 L
- Finitura colore avena
- 3 vetri controporta
- Rastrelliere laterali smontabili a 5 livelli

Cod. LUBE
072560Q43

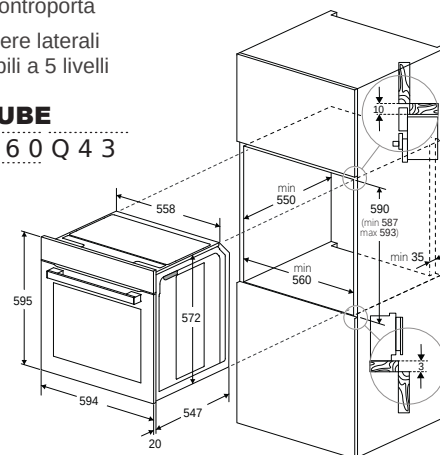

FUNZIONI DI COTTURA

- 8 funzioni di cottura
- Resistenza circolare su ventola

CODICE SAP
7791686707

CODICE EAN
8690842548222

CODICE SAP
7791686710

CODICE EAN
8690842549304

LINEA ESTETICA BASIC

Le caratteristiche essenziali definiscono il suo funzionamento e la sua utilità.

Estetica e facilità d'uso per una cottura sempre ottimale.

BBIC1100B

Forno **Statico**
con **ventilazione tangenziale**



Pulizia a vapore
HydroClean

CARATTERISTICHE PRINCIPALI

- b100
- 2 manopole meccaniche
- Volume cavità 74 L
- Finitura nero
- 2 vetri controporta

FUNZIONI DI COTTURA

- 3 funzioni di cottura

Cod. LUBE
072160Q11

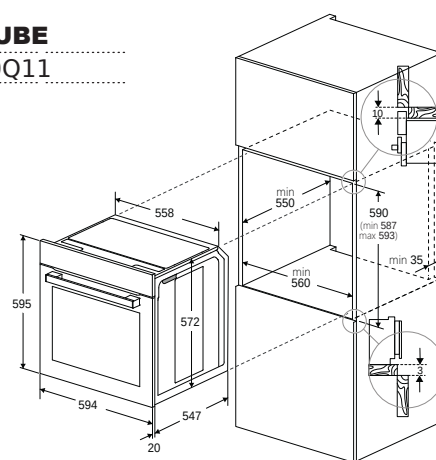

CODICE SAP
7757883860

CODICE EAN
8690842516856

BBIC1400X

Forno **Statico**
con **ventilazione tangenziale**



BBIGT21100X

Forno a **gas con grill elettrico**
e **ventilazione tangenziale**



Pulizia a vapore
HydroClean

CARATTERISTICHE PRINCIPALI

- b100
- 2 manopole meccaniche
- Volume cavità 74 L
- Finitura nero e acciaio inox
- 2 vetri controporta

Cod. LUBE

072160Q04

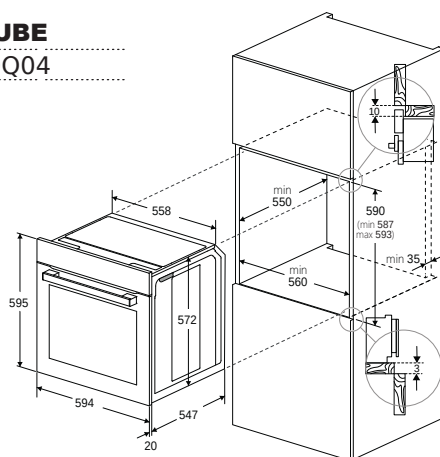

FUNZIONI DI COTTURA

- 3 funzioni di cottura

CARATTERISTICHE PRINCIPALI

- b100
- 3 manopole meccaniche
- Volume cavità 72 L
- Finitura nero e acciaio inox
- 2 vetri controporta

Cod. LUBE

072360Q73

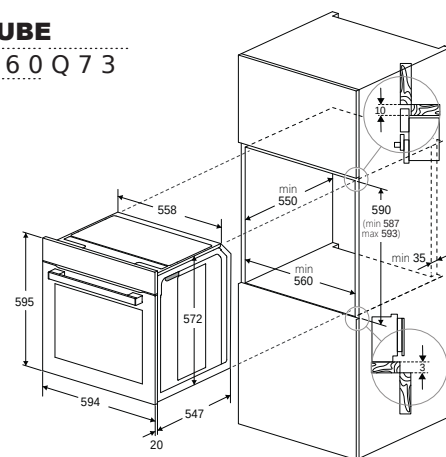

CODICE SAP
7757883815

CODICE EAN
8690842428005

CODICE SAP
7779420261

CODICE EAN
8690842591914

BBCW13400X

Forno **Compatto Multifunzione combinato microonde**



BDRW11400FX

Cassetto scaldavivande



Pulizia a vapore
HydroClean



Microonde

CARATTERISTICHE PRINCIPALI

- bPRO500
- Display LED Direct Access Touch con manopola centrale
- Volume cavità 48 L
- Finitura cristallo nero e acciaio inox
- 3 vetri controporta
- Rastrelliere laterali smontabili a 3 livelli

Cod. LUBE
07306082

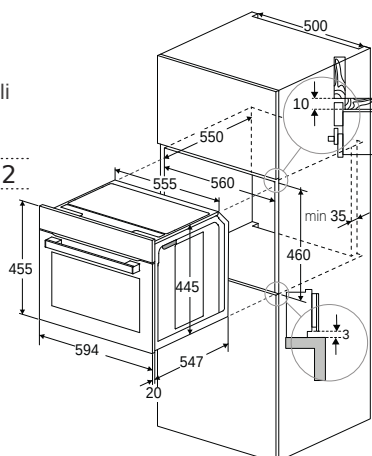

FUNZIONI DI COTTURA

- 10 funzioni di cottura, funzione microonde e 5 funzioni combinate
- Funzione pizza
- Resistenza circolare su ventola

CARATTERISTICHE PRINCIPALI

- bPRO500
- 6 livelli di temperatura (min 30°C – max 80 °C)
- Finitura cristallo nero e acciaio inox
- 3 vetri controporta
- Sistema di apertura push-pull

Cod. LUBE
073568A

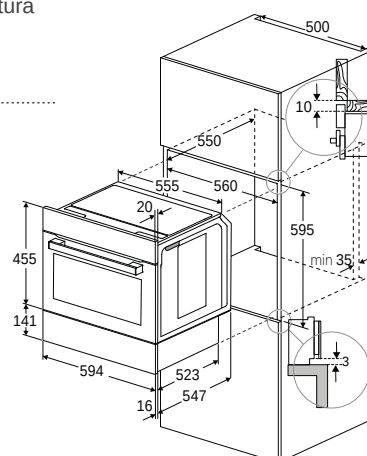

FUNZIONI PRINCIPALI

- 6 funzioni: scongelamento, riscaldamento tazze, mantenimento caldo, rigenerazione e riscaldamento piatti

CODICE SAP 7758089214 | **CODICE EAN** 8690842490293

CODICE SAP 7757183807 | **CODICE EAN** 8690842406638



BMGB25333BG

Forno a **microonde**
con **grill elettrico**



BMGB25332BG

Forno a **microonde**
con **grill elettrico**



Microonde



Microonde

CARATTERISTICHE PRINCIPALI

- Display LCD
- Volume cavità 25 L
- Finitura cristallo nero
- Timer digitale
- 5 livelli di potenza microonde
- 4 livelli di potenza grill
- Potenza max grill: 1kW
- Potenza max microonde: 0.9kW
- Sicurezza bambini

Cod. LUBE
073060Q11

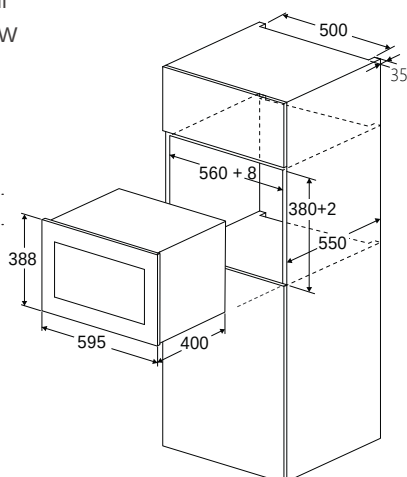

FUNZIONI DI COTTURA

- 9 funzioni di cottura automatica

CARATTERISTICHE PRINCIPALI

- Display LCD
- Volume cavità 25 L
- Finitura inox
- Timer digitale
- 5 livelli di potenza microonde
- 4 livelli di potenza grill
- Potenza max grill: 1kW
- Potenza max microonde: 0.9kW
- Sicurezza bambini

Cod. LUBE
073060Q12

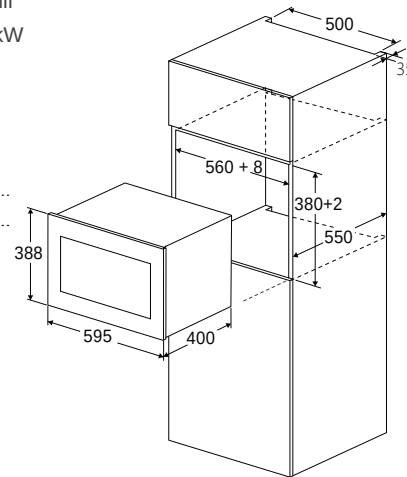

FUNZIONI DI COTTURA

- 9 funzioni di cottura automatica

CODICE SAP 8897373200 | **CODICE EAN** 8690842400766

CODICE SAP 8899893200 | **CODICE EAN** 8690842428937

BMOB17131X

Forno a **microonde**
per installazione a pensile



Microonde

CARATTERISTICHE PRINCIPALI

- Display LCD
- Volume cavità 17 L
- Finitura inox
- Timer digitale
- 5 livelli di potenza microonde
- Potenza max microonde: 0.9kW
- Sicurezza bambini

Cod. LUBE

073060Q13

FUNZIONI DI COTTURA

- 8 funzioni di cottura automatica

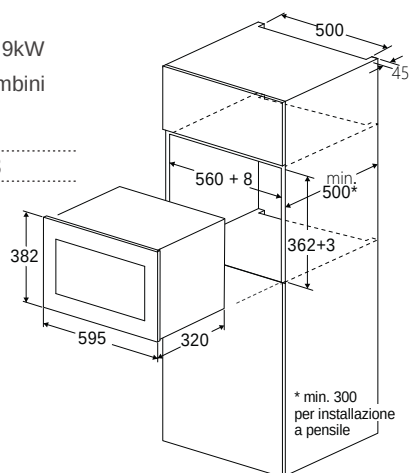

CODICE SAP
8897343200

CODICE EAN
8690842400742





GUIDE TELESCOPICHE AD UN LIVELLO
ROB.MA.17000K6BMS



CODICE SAP
4480100203

Cod. LUBE
073565A

GUIDE TELESCOPICHE A TRE LIVELLI
ROB.MA.17000K6BMS



CODICE SAP
4480100201

Cod. LUBE
073565B



GAMMA FORNI

VAPORE

bPRO500 - Vapore SteamAid™

Midnight	DeepBlack™	Nature
		
MBBIS10600MTMSE	BCBISA17400KSBMPS	BBIS13400XMSWAE

PIROLITICI

bPRO700	bPRO500	
Nature	Midnight	DeepBlack™
		
BBIM13500XPSW	MBBIMA10600MTPSWE	BCBISA17400KSBMPS

AIRFRY

bPRO500

Midnight	DeepBlack™	DeepBlack™
		
MBBIMA10600MTPSWE	BCBISA17400KSBMPS	BCBIMA17400KSBS

b300 - Vapore SteamAssist®

DeepBlack™



BC BIS17300KSB CS

Nature



BB IS13300XM SE

Shine



BB IS14300XE

bPRO500

bPRO300

Dark Inox



BB IM13400DXMP SE

Nature



BB IE13301XMP

Shine



BB IE12301XMP

bPRO300

DeepBlack™



BC BIS17300KSB CS

Nature



BB IMA13300XS

Shine



BB IMA12300X

UN PIANO PERFETTO PER OGNI TUA IDEA DI CUCINA.

L' ESTETICA INCONTRA LA FUNZIONALITÀ.

La nuova linea Midnight per i piani a induzione rappresenta l'evoluzione estetica e funzionale del design, integrandosi perfettamente nelle cucine moderne e coordinandosi armoniosamente con gli altri elettrodomestici della stessa collezione.

I nostri nuovi piani con cappa integrata Beko sono il perfetto connubio fra design e praticità, facendoti risparmiare spazio in cucina senza rinunciare a prestazioni ottimali.

Nel segno di facilità d'uso, intuitività e massima precisione, **i pannelli di controllo Touch Direct Control™+, Touch Direct Control™ e Touch Slider spaziano da 18 a 9 livelli di cottura**, aiutandoti a selezionare facilmente temperatura e tempi desiderati per ogni preparazione.

Pentole o padelle troppo grandi? Le **soluzioni IndyFlex® e IndyFlex+® permettono di comporre zone cottura di diverse dimensioni** in funzione di tutte le esigenze. Per chi è attento alle tariffe energetiche, la **funzione Power Mangement** consente invece di impostare comodamente **i limiti di consumo**.

Preferisci i modelli a gas? Con la **tecnologia Flame Adjust** puoi regolare la fiamma attraverso **9 livelli di intensità**, per una cottura sempre a puntino.

Sul versante di estetica e igiene, il **trattamento PractiClean garantisce un design invidiabile e una pulizia impeccabile**.



03



**FAI LA SCELTA GIUSTA,
SCEGLI IL DESIGN.**

MHII98810NTMT

Piano cottura a induzione
Midnight 90 cm



MHII88810NTIMT

Piano cottura a induzione
Midnight 80 cm



Da installare esclusivamente su basi predisposte per PC ad induzione. Si consiglia l'abbinamento con cappe specifiche per l'induzione



Touch Direct Control™+

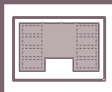

3 sezioni IndyFlex+®



Power Management



Funzione Move



Timer



Booster



Stop&Go



Touch Direct Control™+

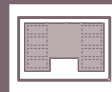

2 sezioni IndyFlex+®



Power Management



Funzione Move



Timer



Booster



Stop&Go



Connettività Wi-Fi HomeWhiz®

CARATTERISTICHE PRINCIPALI

- 11 zone cottura, 3 sezioni IndyFlex+®, 2 extension
- 15 livelli di cottura
- Menù automatici
- Indicatore di accensione/spengimento
- Sicurezza extraflusso
- Spegnimento automatico
- Sistema di sicurezza in caso di surriscaldamento
- Indicatore calore residuo
- EasyFit
- Installabile filo top
- Potenza: 10,8 kW

Cod. LUBE

0 7 4 5 6 2 Q 9 W
FILO.TOP0.7.4.5.6.2.Q.9.W.F

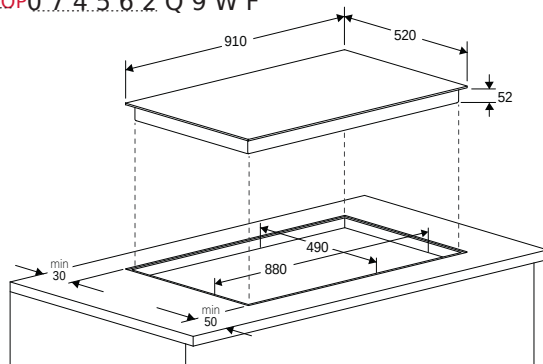

Schemi per incasso filo top da pagina 70

Disponibile da
Marzo 2025

CODICE SAP
7757187731

CODICE EAN
8690842640100

CARATTERISTICHE PRINCIPALI

- 8 zone cottura, 2 sezioni IndyFlex+®, 2 extension
- 15 livelli di cottura
- Menù automatici
- Indicatore di accensione/spengimento
- Sicurezza extraflusso
- Spegnimento automatico
- Sistema di sicurezza in caso di surriscaldamento
- Indicatore calore residuo
- EasyFit
- Installabile filo top
- Potenza: 7,4 kW

Cod. LUBE

0 7 4 5 6 2 Q 9 X
FILO.TOP0.7.4.5.6.2.Q.9.X.F

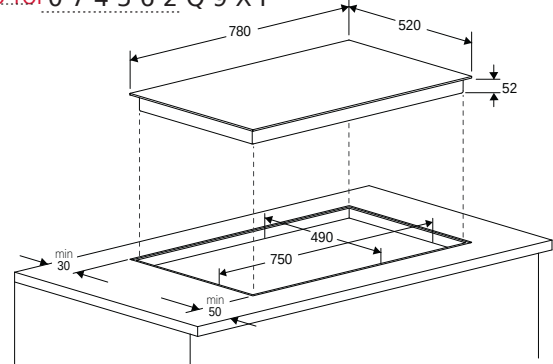

Schemi per incasso filo top da pagina 70

Disponibile da
Marzo 2025

CODICE SAP
7757187723

CODICE EAN
8690842638008

MHII68811NTMTI

Piano cottura a induzione

Midnight 60 cm



Da installare esclusivamente su basi predisposte per PC ad induzione. Si consiglia l'abbinamento con cappe specifiche per l'induzione



Touch Direct Control™+

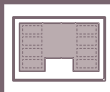

2 sezioni IndyFlex+®



Power Management



Funzione Move



Timer



Booster



Stop&Go



Connettività Wi-Fi HomeWhiz®

CARATTERISTICHE PRINCIPALI

- 8 zone cottura, 2 sezioni IndyFlex+®, 1 extension
- 15 livelli di cottura
- Menù automatici
- Indicatore di accensione/spegnimento
- Sicurezza extraflusso
- Spegnimento automatico
- Sistema di sicurezza in caso di surriscaldamento
- Indicatore calore residuo
- EasyFit
- Installabile filo top
- Potenza: 7,4 kW

Cod. LUBE

0 7 4 5 6 0 Q 8 Y
 FILO.TOP 0 7 4 5 6 0 Q 8 Y F

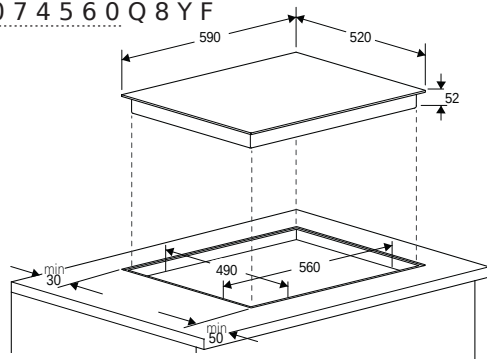

Schemi per incasso filo top da pagina 70

Disponibile da
 Marzo 2025

CODICE SAP
 7757187736

CODICE EAN
 8690842731129

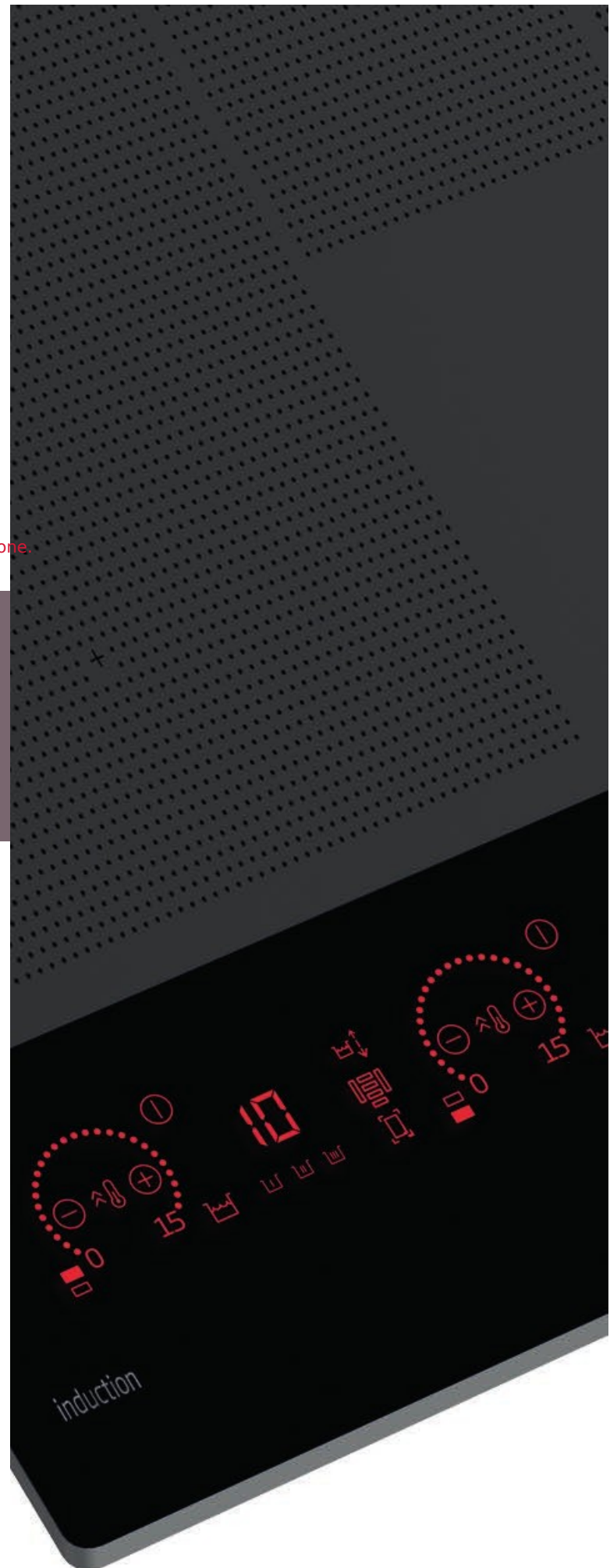



HIXI84700UF

Piano cottura a induzione
con **cappa integrata 80 cm**



Cod. LUBE

0 7 4 5 6 2 Q 8 W

Cod. LUBE

FILQ.TOP 0 7 4 5 6 2 Q 8 W F

HIXI64700UF

Piano cottura a induzione
con **cappa integrata 60 cm**



Cod. LUBE

0 7 4 5 6 0 Q 8 U

Cod. LUBE

FILQ.TOP 0 7 4 5 6 0 Q 8 U F



Touch Slider



1 sezione
IndyFlex®



Power
Management



Timer



Booster



Stop&Go



Inverter



Touch Slider



1 sezione
IndyFlex®



Power
Management



Timer



Booster



Stop&Go



Inverter

CARATTERISTICHE PRINCIPALI

- Cappa aspirante integrata
- 9 livelli di cottura
- 4 zone cottura, 1 sezione IndyFlex®
- 4 livelli di potenza aspirante
- Capacità di ventilazione minima-massima intensiva: 180-530- 630 m³/h
- Rumorosità livello minimo-massimo intensivo: 44-69-73 dBA
- Filtri carbone inclusi

CARATTERISTICHE TECNICHE

- Blocco display
- Indicatore di accensione/spengimento
- Sicurezza extraflusso
- Sicurezza in caso di surriscaldamento
- Spegnimento automatico
- Indicatore calore residuo
- EasyFit
- Installazione filo top
- Potenza elettrica: 7,4 kW

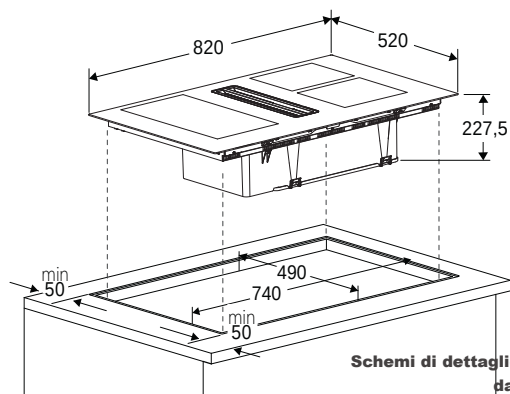

Schemi di dettaglio installazione da pagina 58

CODICE SAP
7757183620

CODICE EAN
8690842642913

CARATTERISTICHE PRINCIPALI

- Cappa aspirante integrata
- 9 livelli di cottura
- 4 zone cottura, 1 sezione IndyFlex®
- 4 livelli di potenza aspirante
- Capacità di ventilazione minima-massima intensiva: 190-520-620 m³/h
- Rumorosità livello minimo-massimo intensivo: 45-69-73 dBA
- Filtri carbone inclusi

CARATTERISTICHE TECNICHE

- Blocco display
- Indicatore di accensione/spengimento
- Sicurezza extraflusso
- Sicurezza in caso di surriscaldamento
- Spegnimento automatico
- Indicatore calore residuo
- EasyFit
- Installazione filo top
- Potenza elettrica: 7,4 kW

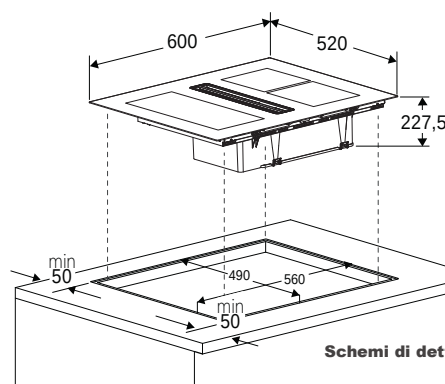

Schemi di dettaglio installazione da pagina 58

CODICE SAP
7757183621

CODICE EAN
8690842642920

INSTALLAZIONE A FILTRANTE

A3

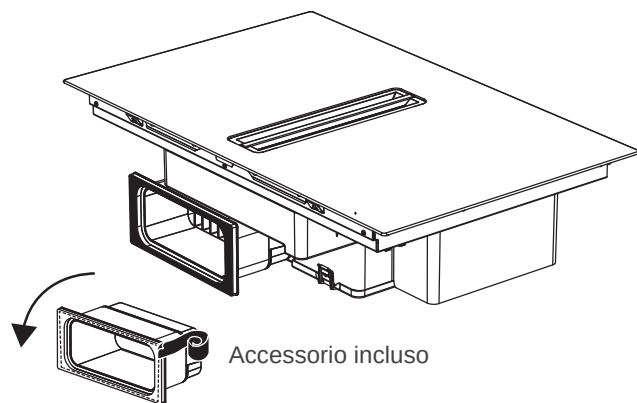

SCHEMA INSTALLAZIONE HIXI84700UF

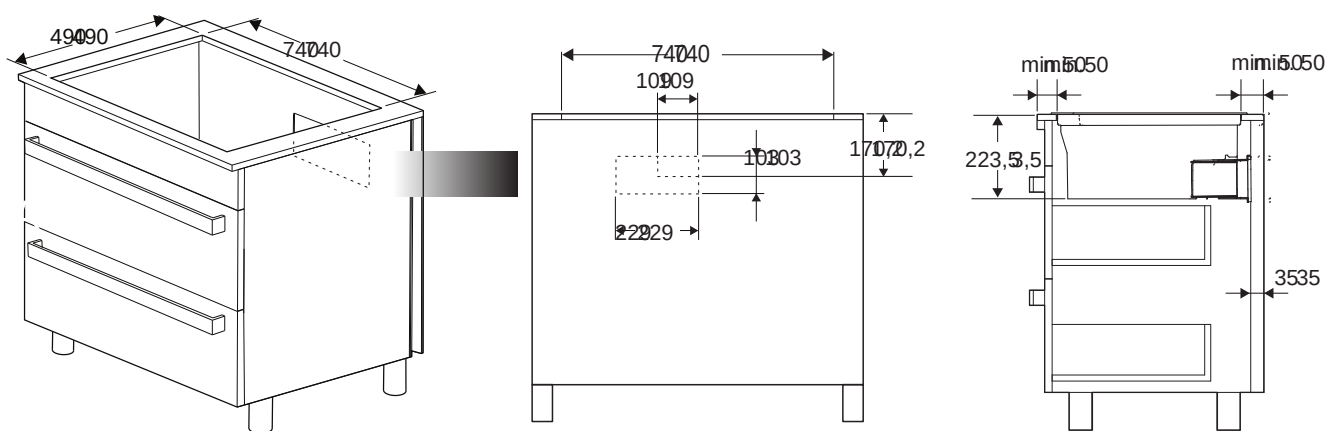

SCHEMA INSTALLAZIONE HIXI64700UF

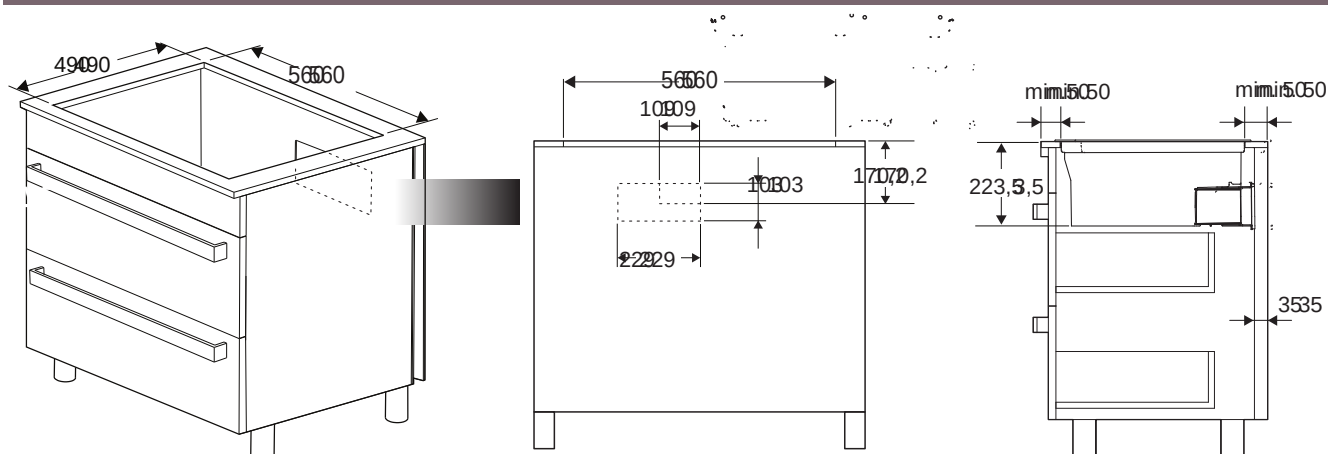

4

ACCESSORI INCLUSI

FILTRI CARBONE



RICAMBIO FILTRI CARBONE - BFHC22645

CODICE SAP
4480100192

CODICE EAN
8690842543494

ACCESSORIO PER ESPULSIONE FUMI SU VUOTO SANITARIO POSTERIORE



INSTALLAZIONE RIFILTRANTE

SCHEMA INSTALLAZIONE HIXI84700UF

SCHEMA INSTALLAZIONE HIXI64700UF

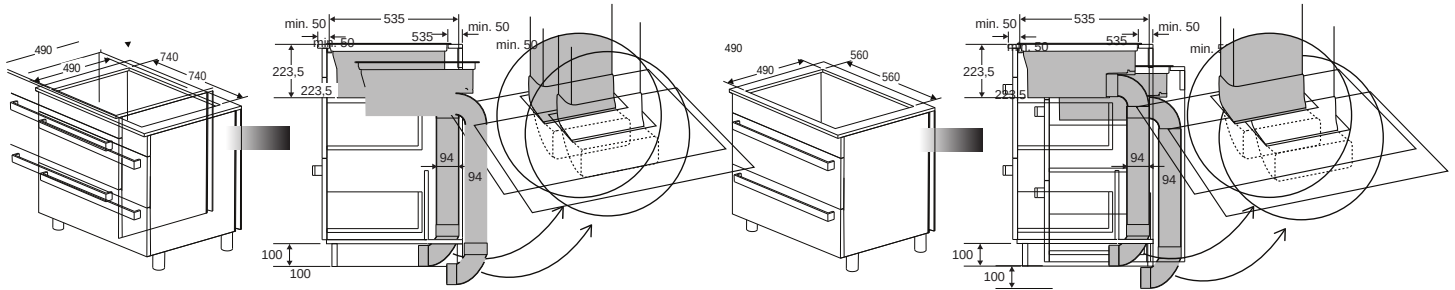

ACCESSORI INCLUSI

FILTRI CARBONE



RICAMBIO FILTRI CARBONE - BFHC22645

CODICE SAP
4480100192

CODICE EAN
8690842543494

ACCESSORI NON INCLUSI

KIT DI INSTALLAZIONE DA ORDINARE SEPARATAMENTE PER ZOCCOLO CUCINA >= 10 CM

CODICE SAP
4480100211

Cod. LUBE
08752704

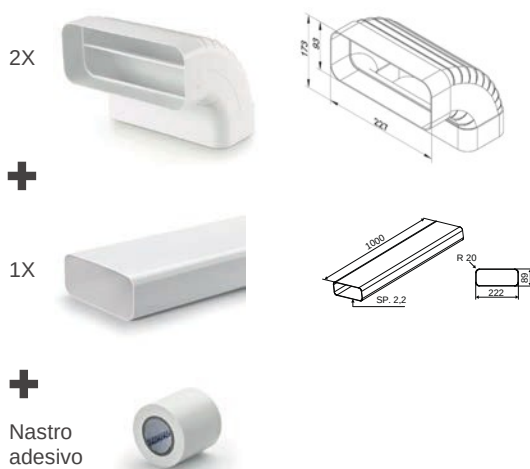

KIT DI INSTALLAZIONE DA ORDINARE SEPARATAMENTE PER ZOCCOLO CUCINA >= 6 CM

CODICE SAP
110265038

Cod. LUBE
08752703

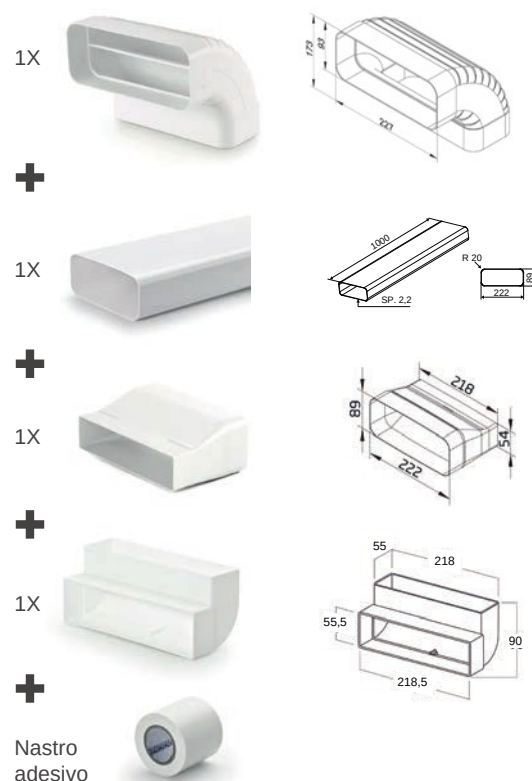

INSTALLAZIONE CASSAPRANTE

SCHEMA INSTALLAZIONE HIXI84700UF

SCHEMA INSTALLAZIONE HIXI64700UF

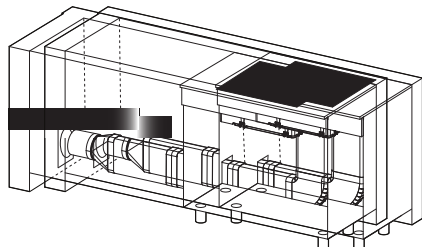
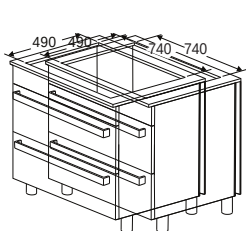

Esempio

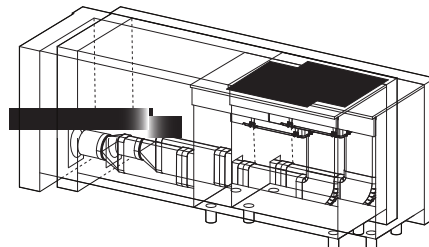
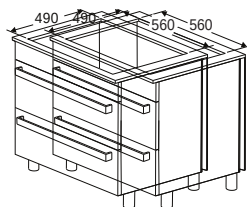

Esempio

ACCESSORI INCLUSI

TUBO FLESSIBILE

CODICE SAP
4480100187

Cod. LUBE
08752705H



TUBO RETTANGOLARE

CODICE SAP
4480100181

Cod. LUBE
08752705B

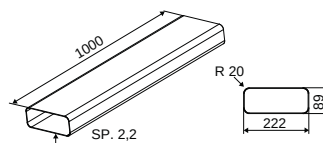

TUBO ROTONDO 350 MM

CODICE SAP
4480100218

Cod. LUBE
08752705L

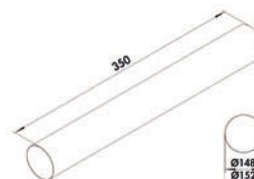

TUBO ROTONDO 1000 MM

CODICE SAP
4480100219

Cod. LUBE
08752705M

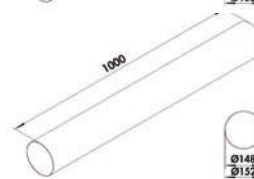

CONNETTORE TUBO ROTONDO

CODICE SAP
4480100220

Cod. LUBE
08752705N

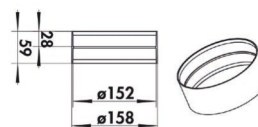

CONNETTORE TUBO RETTANGOLARE

CODICE SAP
4480100182

Cod. LUBE
08752705C

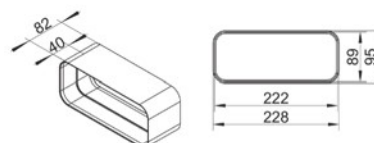

CURVA 15 GRADI

CODICE SAP
4480100175

Cod. LUBE
08752705A

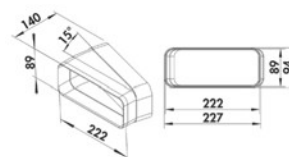

CURVA ORIZZONTALE

CODICE SAP
4480100183

Cod. LUBE
08752705D

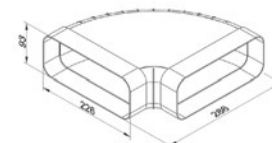

**CURVA A GOMITO TONDO
RETTANGOLARE**

CODICE SAP
4480100184

Cod. LUBE
08752705E

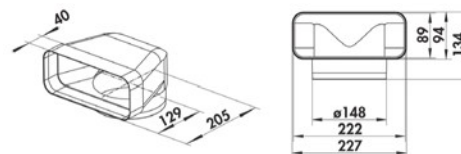

**CURVA A GOMITO
RETTANGOLARE**

CODICE SAP
4480100185

Cod. LUBE
08752705F

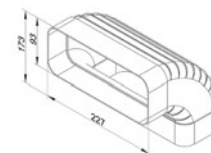

**ADATTATORE TONDO
RETTANGOLO**

CODICE SAP
4480100186

Cod. LUBE
08752705G

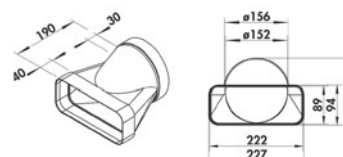

HII98810NT

Piano cottura a induzione

90 cm



HII88810NTI

Piano cottura a induzione

80 cm



Da installare esclusivamente su basi predisposte per PC ad induzione. Si consiglia l'abbinamento con cappe specifiche per l'induzione



Touch Direct Control™+

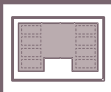

3 sezioni IndyFlex+®



Power Management



Funzione Move



Timer



Booster



Stop&Go



Touch Direct Control™+

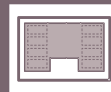

2 sezioni IndyFlex+®



Power Management



Funzione Move



Timer



Booster



Stop&Go



Connettività Wi-Fi HomeWhiz®

CARATTERISTICHE PRINCIPALI

- 11 zone cottura, 3 sezioni IndyFlex+®, 2 extension
- 15 livelli di cottura
- Menù automatici
- Indicatore di accensione/spengimento
- Sicurezza extraflusso
- Spegnimento automatico
- Sistema di sicurezza in caso di surriscaldamento
- Indicatore calore residuo
- EasyFit
- Installabile filo top
- Potenza: 10,8 kW

Cod. LUBE

0 7 4 5 6 2 Q 9 V

FILQ.TOP0 7 4 5 6 2 Q 9 V F

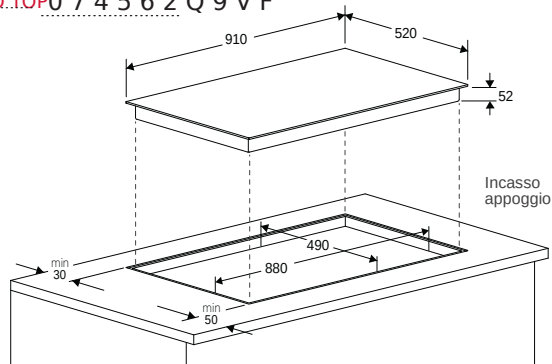

Schemi per incasso filo top da pagina 70

CODICE SAP
7757187733

CODICE EAN
8690842727566

CARATTERISTICHE PRINCIPALI

- 8 zone cottura, 2 sezioni IndyFlex+®, 2 extension
- 15 livelli di cottura
- Menù automatici
- Indicatore di accensione/spengimento
- Sicurezza extraflusso
- Spegnimento automatico
- Sistema di sicurezza in caso di surriscaldamento
- Indicatore calore residuo
- EasyFit
- Installabile filo top
- Potenza: 7,4 kW

Cod. LUBE

0 7 4 5 6 2 Q 9 R

FILQ.TOP0 7 4 5 6 2 Q 9 R F

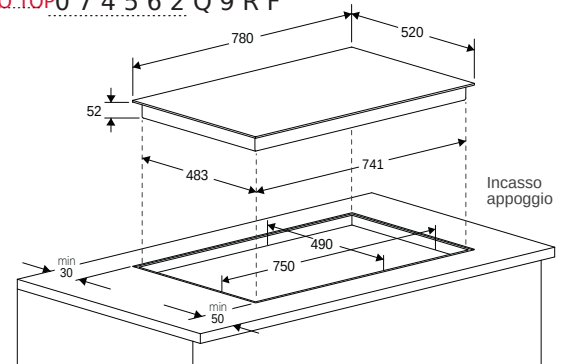

Schemi per incasso filo top da pagina 70

CODICE SAP
7757187732

CODICE EAN
8690842727412

HII85780UFT

Piano cottura a induzione

80 cm

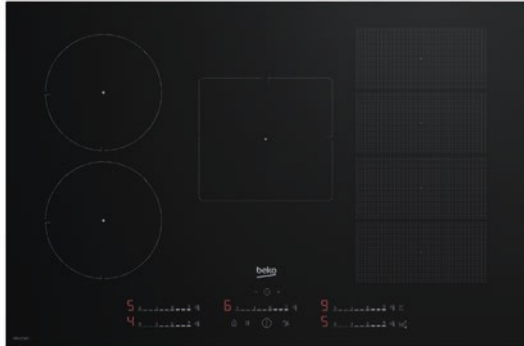

HII84541IFT

Piano cottura a induzione

80 cm

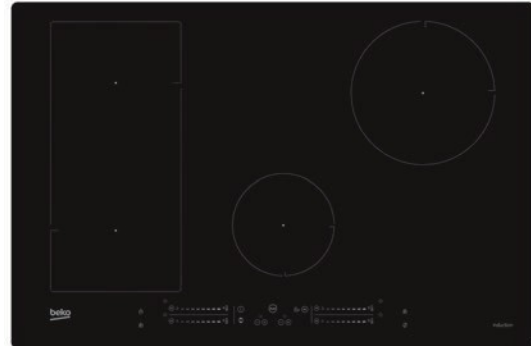

Da installare esclusivamente su basi predisposte per PC ad induzione. Si consiglia l'abbinamento con cappe specifiche per l'induzione



Touch Slider



1 sezione IndyFlex[®]



Power Management



Funzione Move



Touch Slider



1 sezione IndyFlex[®]



Power Management



Timer



Timer



Booster



Stop&Go



Booster



Stop&Go

CARATTERISTICHE PRINCIPALI

- 8 zone cottura, 1 sezione IndyFlex[®]
- 9 livelli di cottura
- Blocco display
- Indicatore di accensione/spengimento
- Sicurezza extraflusso
- Spegnimento automatico
- Sistema di sicurezza in caso di surriscaldamento
- Indicatore calore residuo
- EasyFit
- Installabile filo top
- Potenza: 7,4 kW

Cod. LUBE

0 7 4 5 6 2 Q 9 N

FILQ.TOP0 7 4 5 6 2 Q 9 N F

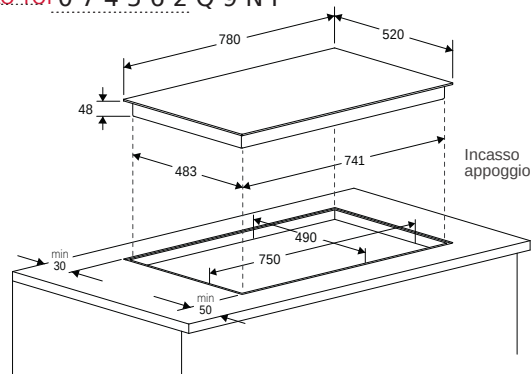

Schemi per incasso filo top da pagina 70

CODICE SAP
7757188716

CODICE EAN
8690842511660

CARATTERISTICHE PRINCIPALI

- 4 zone cottura, 1 sezione IndyFlex[®]
- 18 livelli di cottura
- Menù automatici
- Blocco display
- Indicatore di accensione/spengimento
- Sicurezza extraflusso
- Spegnimento automatico
- Sistema di sicurezza in caso di surriscaldamento
- Indicatore calore residuo
- EasyFit
- Installabile filo top
- Potenza: 7,2 kW

Cod. LUBE

074562Q9S

FILQ.TOP0 7 4 5 6 2 Q 9 S F

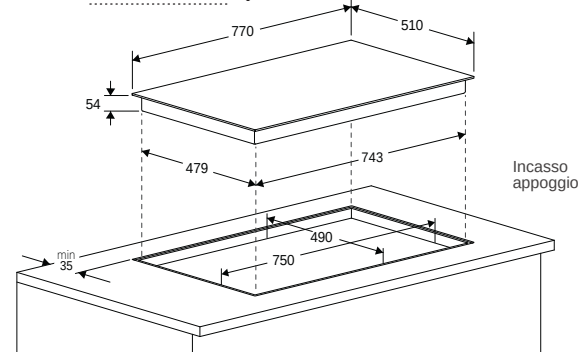

Schemi per incasso filo top da pagina 70

CODICE SAP
869991698920

CODICE EAN
8690842745560

HII74700UF

Piano cottura a induzione

70 cm



Da installare esclusivamente su basi predisposte per PC ad induzione. Si consiglia l'abbinamento con cappe specifiche per l'induzione



Touch Slider



1 sezione IndyFlex®



Power Management



Timer



Booster



Stop&Go

CARATTERISTICHE PRINCIPALI

- 4 zone cottura, 1 sezione IndyFlex®
- 9 livelli di cottura
- Blocco display
- Indicatore di accensione/spengimento
- Sicurezza extraflusso
- Spegnimento automatico
- Sistema di sicurezza in caso di surriscaldamento
- Indicatore calore residuo
- EasyFit
- Installabile filo top
- Potenza: 7,4 kW

Cod. LUBE

0 7 4 5 6 2 Q 9 T

FILO.TOP 0 7 4 5 6 2 Q 9 T F

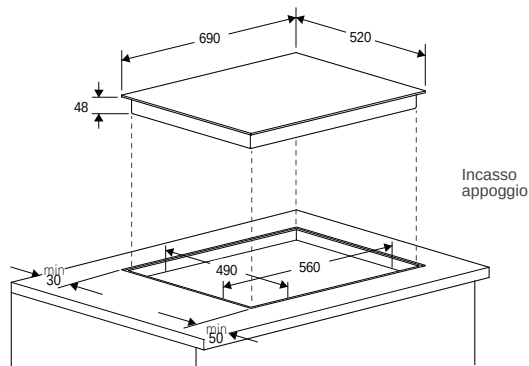

Schemi per incasso filo top da pagina 70

CODICE SAP
7757188684

CODICE EAN
8690842446290



HII68811NT
RCBIMAT7400XSRMPS

Piano cottura a induzione

60 cm

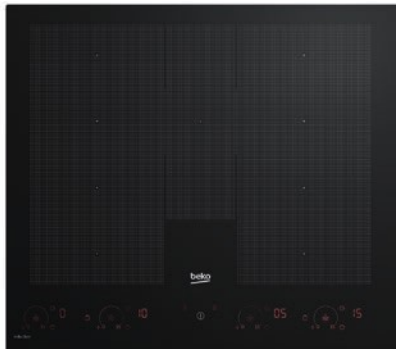

HII64720UF2T

Piano cottura a induzione

60 cm



Da installare esclusivamente su basi predisposte per PC ad induzione. Si consiglia l'abbinamento con cappe specifiche per l'induzione



Touch Direct Control™+



2 sezioni IndyFlex®



Power Management



Funzione Move



Touch Slider



1 sezione IndyFlex®



Power Management



Timer



Timer



Booster



Stop&Go



Booster



Stop&Go

CARATTERISTICHE PRINCIPALI

- 8 zone cottura, 2 sezioni IndyFlex+®, 1 extension
- 15 livelli di cottura
- Menù automatici
- Indicatore di accensione/ spegnimento
- Sicurezza extraflusso
- Spegnimento automatico
- Sistema di sicurezza in caso di surriscaldamento
- Indicatore calore residuo
- EasyFit
- Installabile filo top
- Potenza: 7,4 kW

Cod. LUBE

074560Q85

FILO.TOP074560Q85F

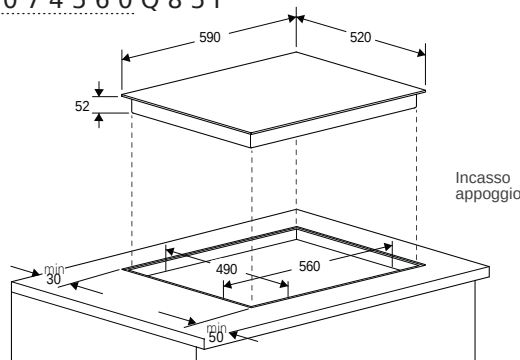

Schemi per incasso filo top da pagina 70

CODICE SAP
7757187734

CODICE EAN
869084272467

CARATTERISTICHE PRINCIPALI

- 4 zone cottura, 2 sezioni IndyFlex®
- 9 livelli di cottura
- Blocco display
- Indicatore di accensione/ spegnimento
- Sicurezza extraflusso
- Spegnimento automatico
- Sistema di sicurezza in caso di surriscaldamento
- Indicatore calore residuo
- EasyFit
- Installabile filo top
- Potenza: 7,4 kW

Cod. LUBE

074560Q86

FILO.TOP074560Q86F

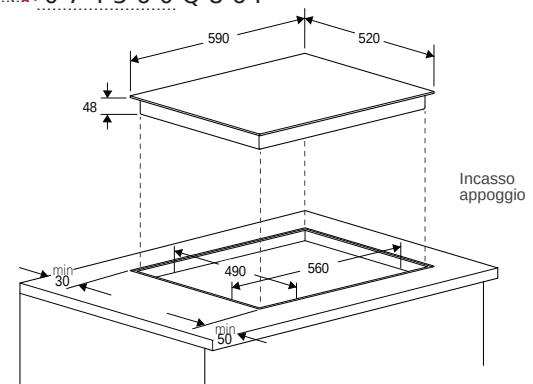

Schemi per incasso filo top da pagina 70

CODICE SAP
7757188686

CODICE EAN
8690842462337

HII64600AFT
RCBMA17400K\$BMPS

Piano cottura a induzione

60 cm



HII64200FMTW

Piano cottura a induzione

60 cm

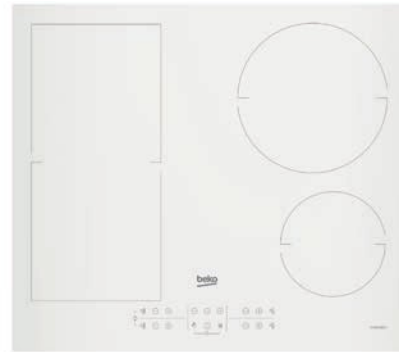

Da installare esclusivamente su basi predisposte per PC ad induzione. Si consiglia l'abbinamento con cappe specifiche per l'induzione



Touch Slider



1 sezione IndyFlex®



Power Management



Timer



Booster



Stop&Go



Touch Direct Control™



1 sezione IndyFlex®



Power Management



Timer



Booster



Stop&Go

CARATTERISTICHE PRINCIPALI

- 4 zone cottura, 1 sezione IndyFlex®
- 9 livelli di cottura
- Blocco display
- Indicatore di accensione/spengimento
- Sicurezza extraflusso
- Spegnimento automatico
- Sistema di sicurezza in caso di surriscaldamento
- Indicatore calore residuo
- EasyFit
- Installabile filo top
- Potenza: 7,4 kW

Cod. LUBE

0 7 4 5 6 0 Q 8 7
FILO.TOP 0 7 4 5 6 0 Q 8 7 F

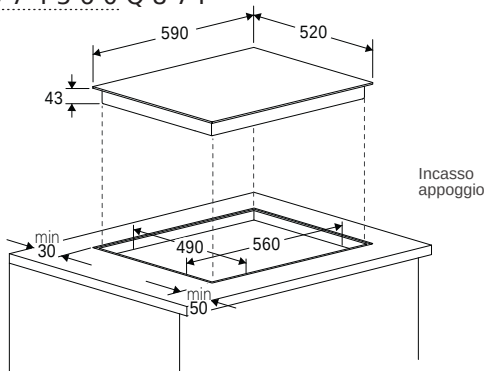

Schemi per incasso filo top da pagina 70

Disponibile da Aprile 2025

CODICE SAP
7757189015

CODICE EAN
8690842701702

CARATTERISTICHE PRINCIPALI

- 4 zone cottura, 1 sezione IndyFlex®
- 9 livelli di cottura
- Blocco display
- Indicatore di accensione/spengimento
- Sicurezza extraflusso
- Spegnimento automatico
- Sistema di sicurezza in caso di surriscaldamento
- Indicatore calore residuo
- EasyFit
- Installabile filo top
- Potenza: 7,4 kW

Cod. LUBE

0 7 4 5 6 0 Q 8 4
FILO.TOP 0 7 4 5 6 0 Q 8 4 F

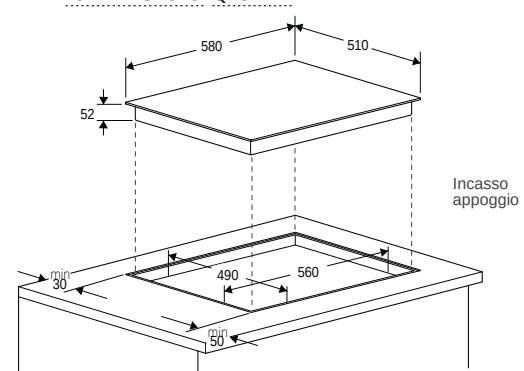

Schemi per incasso filo top da pagina 70

CODICE SAP
7757189227

CODICE EAN
8690842386619

HII642035MT
RCBMA17400KSBMPS

Piano cottura a induzione

60 cm



Da installare esclusivamente su basi predisposte per PC ad induzione. Si consiglia l'abbinamento con cappe specifiche per l'induzione

HII64200MT

Piano cottura a induzione

60 cm



Da installare esclusivamente su basi predisposte per PC ad induzione. Si consiglia l'abbinamento con cappe specifiche per l'induzione



Touch Direct Control™



1 sezione IndyFlex®



Power Management



Timer



Booster



Stop & Go

Stop&Go



Touch Direct Control™



Power Management



Timer



Booster



Stop & Go

Stop&Go

CARATTERISTICHE PRINCIPALI

- 4 zone cottura, 1 sezione IndyFlex®
- 9 livelli di cottura
- Blocco display
- Indicatore di accensione/spengimento
- Sicurezza extraflusso
- Spegnimento automatico
- Sistema di sicurezza in caso di surriscaldamento
- Indicatore calore residuo
- EasyFit
- Installabile filo top
- Potenza: 7,4 kW

Cod. LUBE

074560Q81
FILO.TOP074560Q81F

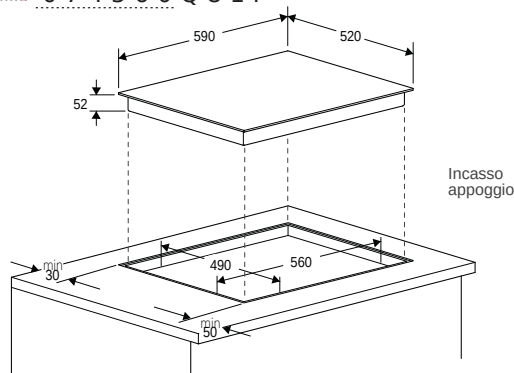

Schemi per incasso filo top da pagina 70

CODICE SAP
7757189257

CODICE EAN
8690842555695

CARATTERISTICHE PRINCIPALI

- 4 zone cottura
- 9 livelli di cottura
- Blocco display
- Indicatore di accensione/spengimento
- Sicurezza extraflusso
- Spegnimento automatico
- Sistema di sicurezza in caso di surriscaldamento
- Indicatore calore residuo
- EasyFit
- Installabile filo top
- Potenza: 7,2 kW

Cod. LUBE

074560Q80
FILO.TOP074560Q80F

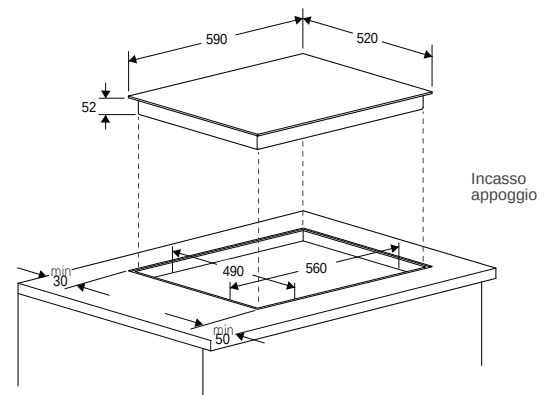

Schemi per incasso filo top da pagina 70

CODICE SAP
7757189212

CODICE EAN
8690842214172



HUG84401
RCRIMA174001KSBMPS

Piano cottura in vetroceramica

80 cm



HUG64401
RCRIMA174001KSBMPS

Piano cottura in vetroceramica

60 cm

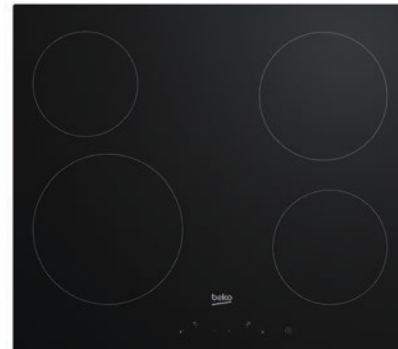

Da installare esclusivamente su basi predisposte per PC ad induzione. Da installare esclusivamente su basi predisposte per PC ad induzione.



Timer



Timer

CARATTERISTICHE PRINCIPALI

- 4 zone cottura
- Comandi Touch con 9 livelli di potenza
- Blocco display
- Indicatore di accensione/spengimento
- Sicurezza extraflusso
- Spegnimento automatico
- Sistema di sicurezza in caso di surriscaldamento
- Indicatore calore residuo
- Installabile filo top
- Potenza: 7,4 kW

Cod. LUBE

0 7 4 5 6 2 Q 9 4

FILQ.TOP0 7 4 5 6 2 Q 9 4 F

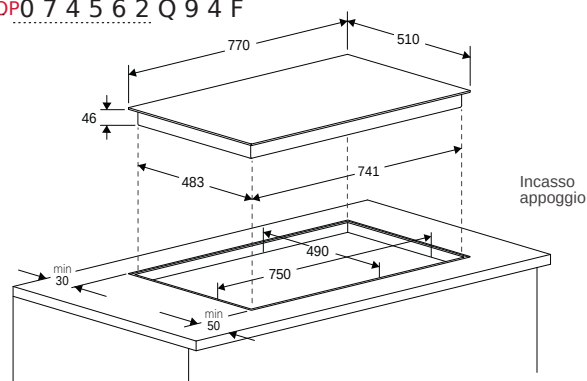

Incasso appoggio

Schemi per incasso filo top da pagina 70

CODICE SAP
7756388632

CODICE EAN
8690842756306

CARATTERISTICHE PRINCIPALI

- 4 zone cottura
- Comandi Touch con 9 livelli di potenza
- Blocco display
- Sicurezza extraflusso
- Spegnimento automatico
- Sistema di sicurezza in caso di surriscaldamento
- Indicatore calore residuo
- Installabile filo top
- Potenza: 6,0 kW

Cod. LUBE

074560Q01

FILQ.TOP074560Q01F

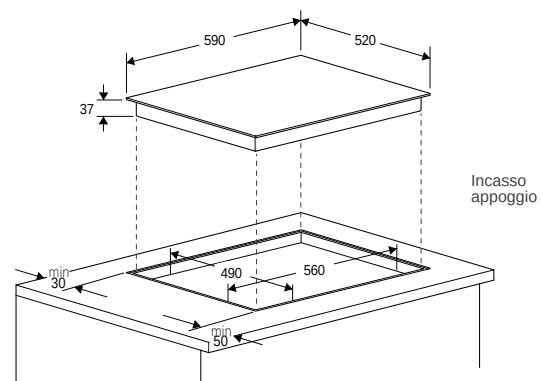

Incasso appoggio

Schemi per incasso filo top da pagina 70

CODICE SAP
7756284307

CODICE EAN
8690842016509

INGASSO FILO TOP

RCRIMA 17400KSEMPs

MODELLI: MHII68811NTMTI - HII68811NT - HII64720UF2T - HII64600AFT - HII64203FMT - HII64200MT

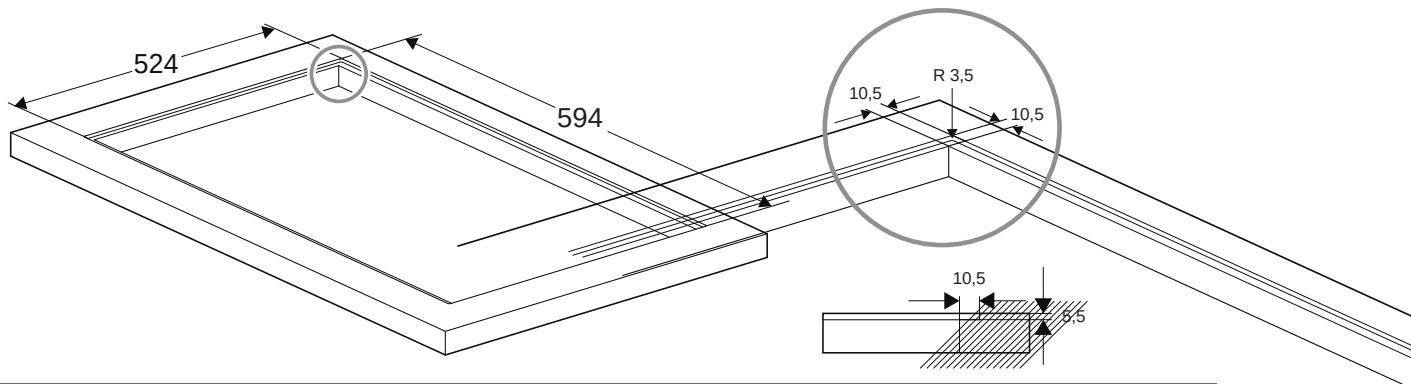

MODELLO: HII74700UF

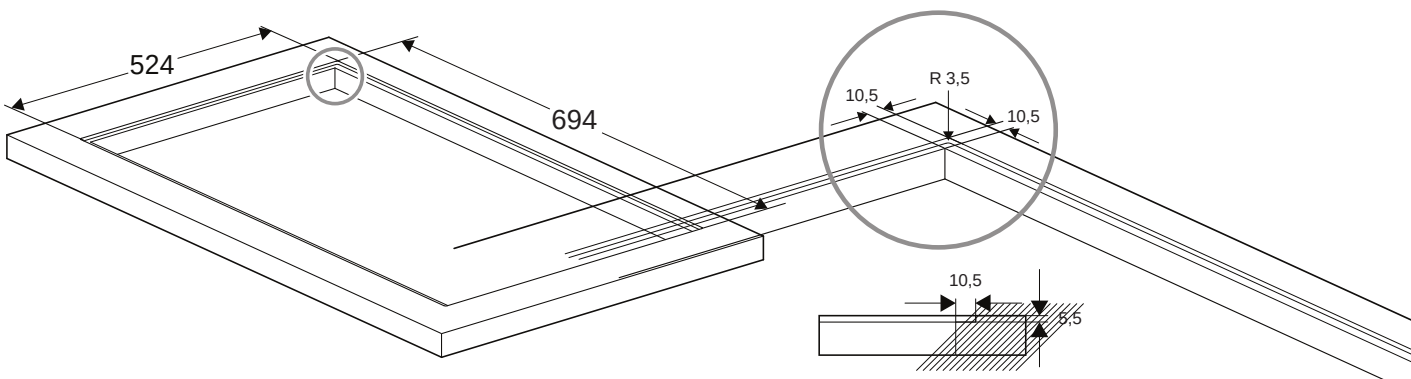

MODELLO: HII84541IFT

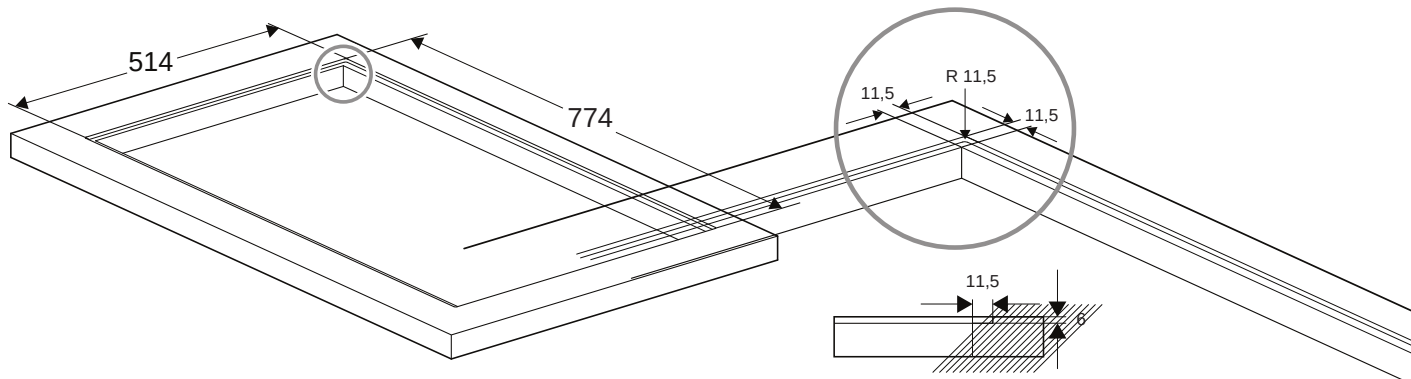

MODELLI: MHII98810NTMT - HII98810NT

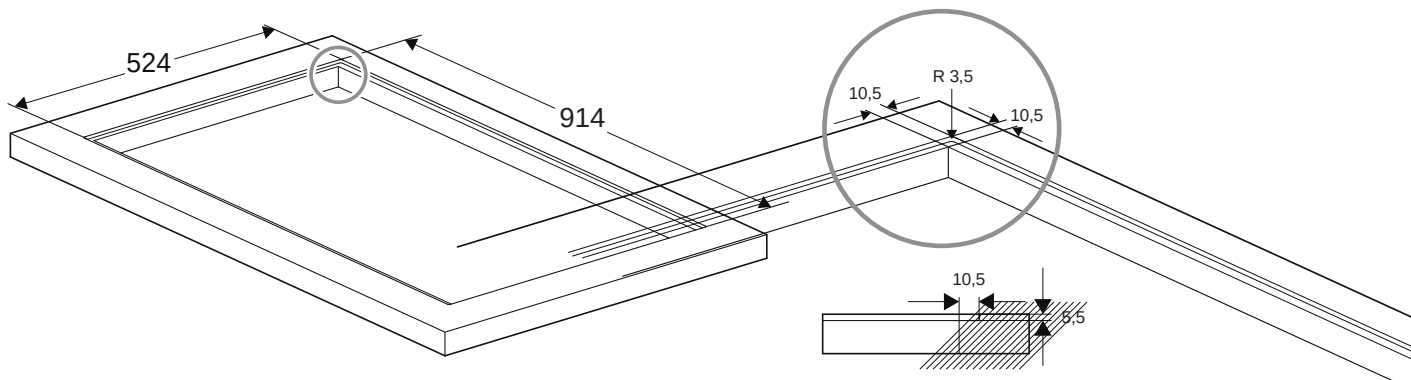

INGASSO FILO TOP
RUBINIA 17400KSEMPs

MODELLO: HIXI64700UF

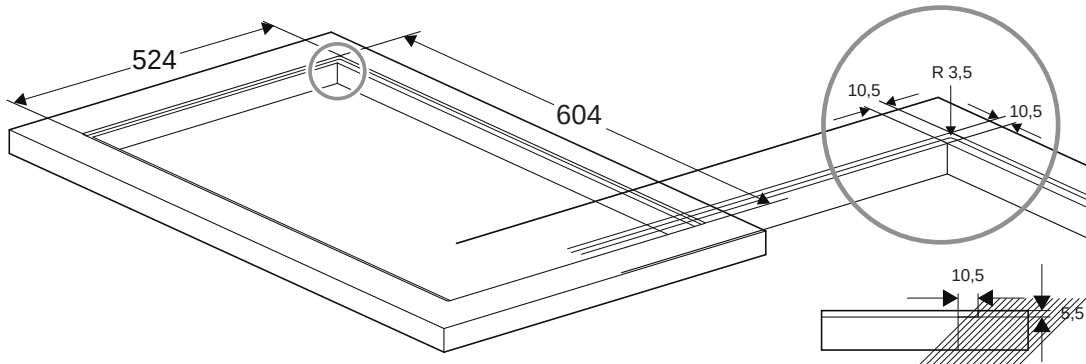

MODELLO: HIXI84700UF

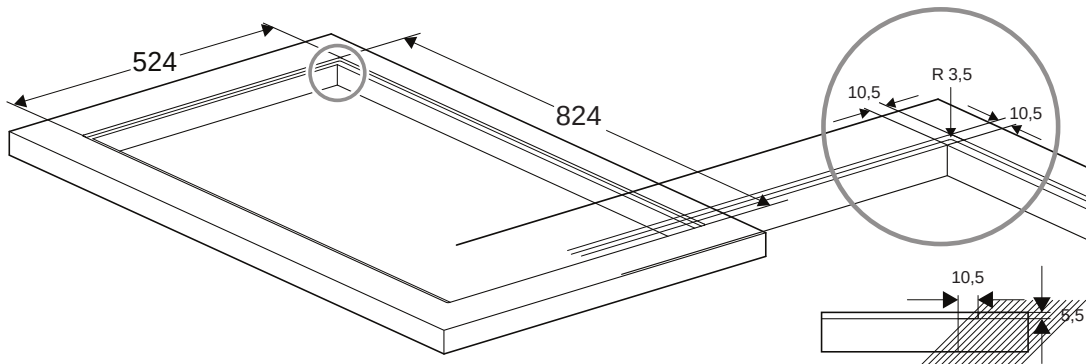

MODELLI: MHII88810NTIMT - HII88810NTI - HII85770UFT

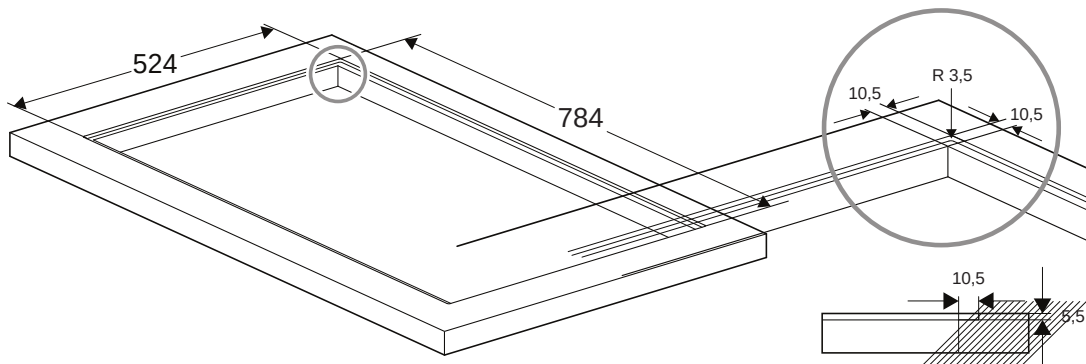

MODELLI: HII64200FMTW - HIC64401

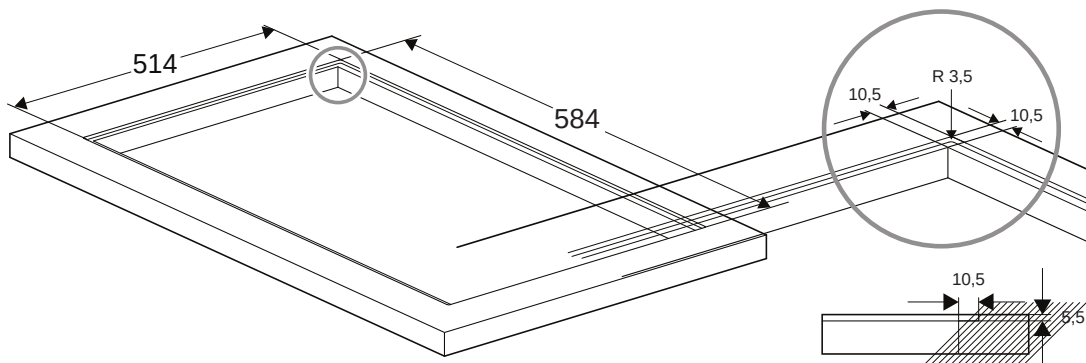



HILW75325SDX

Piano cottura a gas

75 cm



HILG64325SDX

Piano cottura a gas

60 cm



Griglie in ghisa



Doppia corona
5 kW



High efficiency
burner



FlameAdjust



Griglie in ghisa



High efficiency
burner



FlameAdjust

CARATTERISTICHE PRINCIPALI

- Cristallo nero con manopole dark inox
- Comandi frontali
- Anteriore sinistro: 1 kW
- Anteriore destro: 1,75 kW
- Posteriore sinistro: 2,9 kW
- Posteriore destro: 1,75 kW
- Centrale: High Power 5 kW
- Accensione elettronica integrata
- Uso di gas naturale G20-20 mbar
- Adattabile a GPL G30-30 mbar
- Potenza: 12,4 kW

Cod. LUBE

0 7 4 5 7 2 Q 2 1

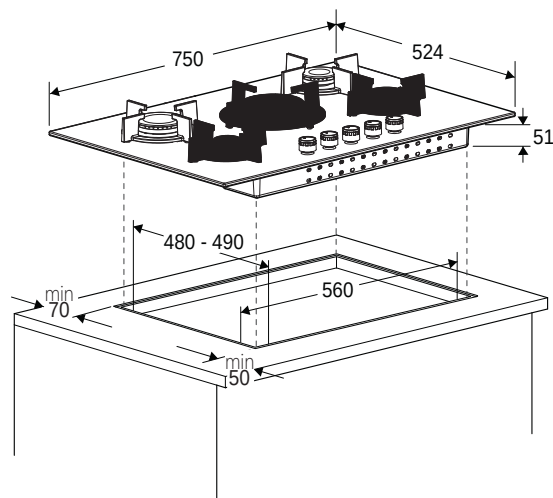

CODICE SAP
7763583809

CODICE EAN
8690842194849

CARATTERISTICHE PRINCIPALI

- Cristallo nero con manopole dark inox
- Comandi frontali
- Anteriore sinistro: 1,75 kW
- Anteriore destro: 1 kW
- Posteriore sinistro: 2,9 kW
- Posteriore destro: 1,75 kW
- Accensione elettronica integrata
- Uso di gas naturale G20-20 mbar
- Adattabile a GPL G30-30 mbar
- Potenza: 7,4 kW

Cod. LUBE

0 7 4 5 6 4 Q 2 7

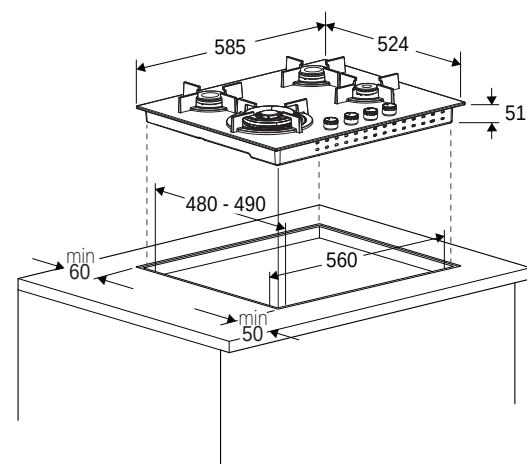

CODICE SAP
7702320143

CODICE EAN
8690842203930

HILL75222S

Piano cottura a gas

75 cm



BCRIMA17477K5BMP5

Piano cottura a gas

75 cm



Griglie in ghisa



Doppia corona
5 kW



High efficiency
burner



Griglie in ghisa



Doppia corona
5 kW



High efficiency
burner

CARATTERISTICHE PRINCIPALI

- Cristallo nero
- Comandi frontali
- Anteriore centrale: 1 kW
- Anteriore destro: 1,75 kW
- Posteriore centrale: 1,75 kW
- Posteriore destro: 2,9 kW
- Sinistro: High Power 5 kW
- Accensione elettronica integrata
- Uso di gas naturale G20-20 mbar
- Adattabile a GPL G30-30 mbar
- Potenza: 12,4 kW

Cod. LUBE

074572Q20

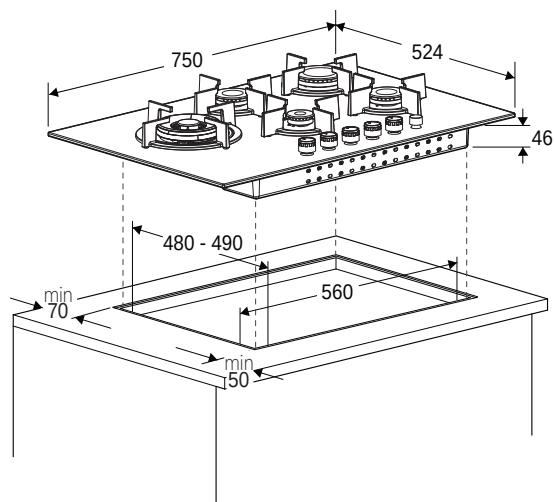

CARATTERISTICHE PRINCIPALI

- Cristallo nero
- Comandi frontali
- Anteriore sinistro: 1 kW
- Anteriore destro: 1,75 kW
- Posteriore sinistro: 2,9 kW
- Posteriore destro: 1,75 kW
- Centrale: High Power 5 kW
- Accensione elettronica integrata
- Uso di gas naturale G20-20 mbar
- Adattabile a GPL G30-30 mbar
- Potenza: 12,4 kW

Cod. LUBE

074572Q16

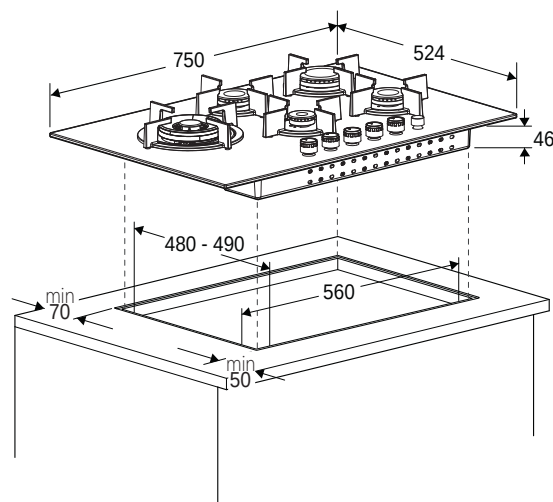

CODICE SAP
7712287640

CODICE EAN
8690842095382

CODICE SAP
7712287620

CODICE EAN
8690842093586

HILG64222S

Piano cottura a gas

60 cm

Griglie in ghisa



High efficiency burner

CARATTERISTICHE PRINCIPALI

- Cristallo nero
- Comandi frontali
- Anteriore sinistro: 1,75 kW
- Anteriore destro: 1 kW
- Posteriore sinistro: 2,9 kW
- Posteriore destro: 1,75 kW
- Accensione elettronica integrata
- Uso di gas naturale G20-20 mbar
- Adattabile a GPL G30-30 mbar
- Dispositivo di sicurezza per assenza di fiamma
- Potenza: 7,4 kW

Cod. LUBE
074564Q14

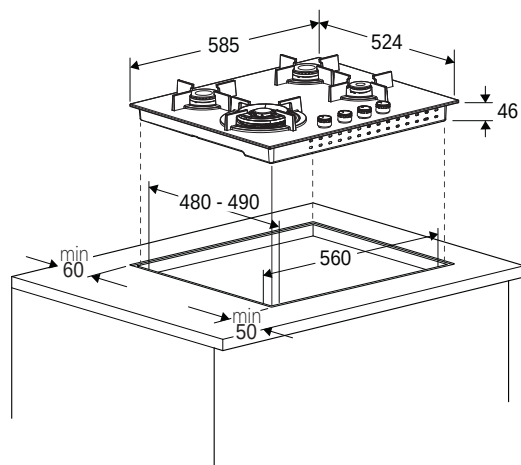

CODICE SAP
7757188647

CODICE EAN
8690842127878



**HILW75222S7C
RCRIMAT/2400K/3EMPS**

Piano cottura a gas

75 cm



HILW75222SW

Piano cottura a gas

75 cm



Griglie in ghisa



Doppia corona
5 kW



High efficiency
burner



Griglie in ghisa



Doppia corona
5 kW



High efficiency
burner

CARATTERISTICHE PRINCIPALI

- Cristallo zara grey
- Comandi frontali
- Anteriore sinistro: 1 kW
- Anteriore destro: 1,75 kW
- Posteriore sinistro: 2,9 kW
- Posteriore destro: 1,75 kW
- Centrale: High Power 5 kW
- Accensione elettronica integrata
- Uso di gas naturale G20-20 mbar
- Adattabile a GPL G30-30 mbar
- Dispositivo di sicurezza per assenza di fiamma
- Potenza: 12,4 kW

Cod. LUBE

0 7 4 5 7 2 Q 2 3

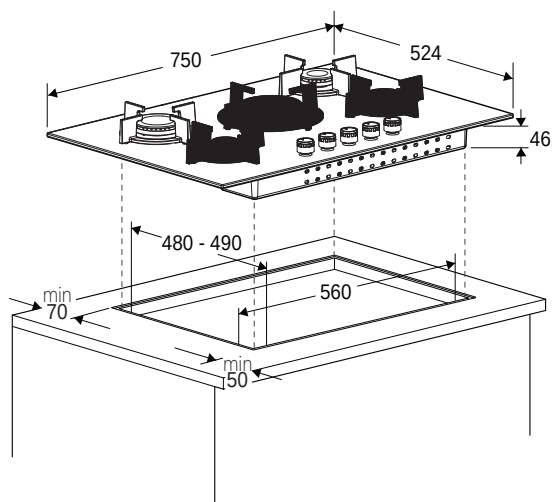

CARATTERISTICHE PRINCIPALI

- Cristallo bianco
- Comandi frontali
- Anteriore sinistro: 1 kW
- Anteriore destro: 1,75 kW
- Posteriore sinistro: 2,9 kW
- Posteriore destro: 1,75 kW
- Centrale: High Power 5 kW
- Accensione elettronica integrata
- Uso di gas naturale G20-20 mbar
- Adattabile a GPL G30-30 mbar
- Potenza: 12,4 kW

Cod. LUBE

0 7 4 5 7 2 Q 2 2

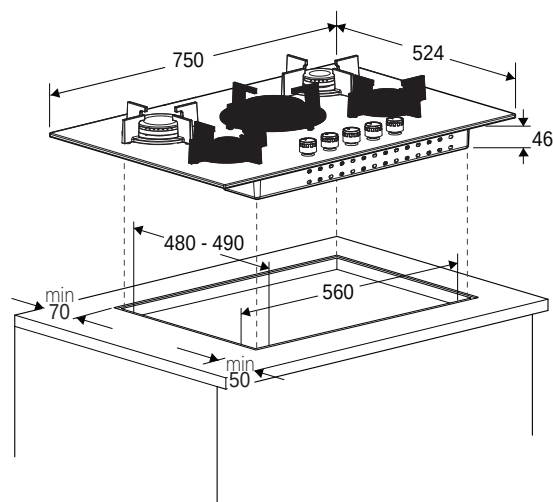

CODICE SAP
7712287623

CODICE EAN
8690842203831

CODICE SAP
7712287622

CODICE EAN
8690842203848

HILG64222SZG
RCRIMA17400R38MPS

Piano cottura a gas

60 cm



HILG64222SW

Piano cottura a gas

60 cm



Griglie in ghisa



High efficiency burner



Griglie in ghisa



High efficiency burner

CARATTERISTICHE PRINCIPALI

- Cristallo zara grey
- Comandi frontali
- Anteriore sinistro: 1,75 kW
- Anteriore destro: 1 kW
- Posteriore sinistro: 2,9 kW
- Posteriore destro: 1,75 kW
- Accensione elettronica integrata
- Uso di gas naturale G20-20 mbar
- Adattabile a GPL G30-30 mbar
- Potenza: 7,4 kW

Cod. LUBE

074564Q28

CARATTERISTICHE PRINCIPALI

- Cristallo bianco
- Comandi frontali
- Anteriore sinistro: 1,75 kW
- Anteriore destro: 1 kW
- Posteriore sinistro: 2,9 kW
- Posteriore destro: 1,75 kW
- Accensione elettronica integrata
- Uso di gas naturale G20-20 mbar
- Adattabile a GPL G30-30 mbar
- Dispositivo di sicurezza per assenza di fiamma
- Potenza: 7,4 kW

Cod. LUBE

074564Q29

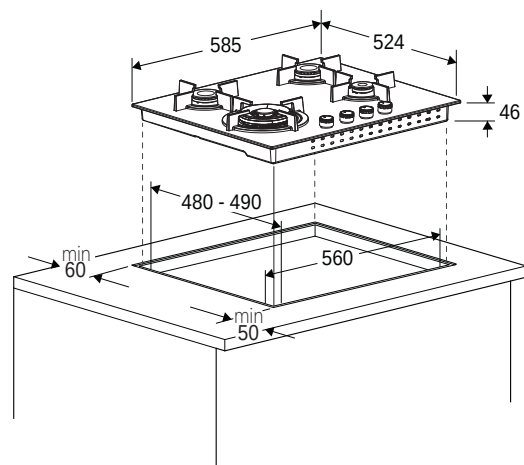
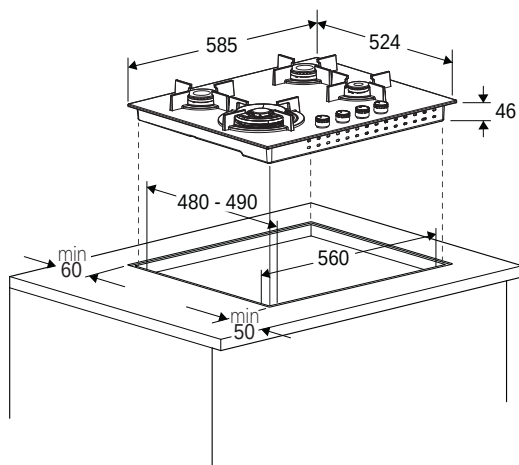

CODICE SAP
7763586719

CODICE EAN
8690842128110

CODICE SAP
7763586723

CODICE EAN
8690842128004

HIAL95225SXE
RCRIMA17400KSEMP5

Piano cottura a gas

90 cm



HIAL75226SXE

Piano cottura a gas

75 cm



Griglie in ghisa



Doppia corona



Griglie in ghisa



Doppia corona
5 kW



High efficiency
burner



FlameAdjust

CARATTERISTICHE PRINCIPALI

- Acciaio Inox
- Comandi frontali
- Anteriore centrale: 1,75 kW
- Anteriore destro: 1 kW
- Posteriore centrale: 1,75 kW
- Posteriore destro: 2,9 kW
- Sinistro: 3,8 kW
- Accensione elettronica integrata
- Uso di gas naturale G20-20 mbar
- Adattabile a GPL G30-30 mbar
- Dispositivo di sicurezza per assenza di fiamma

Cod. LUBE
075094Q41

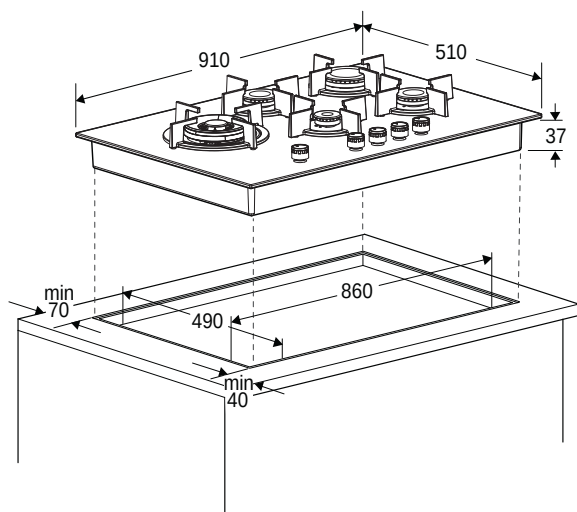

CODICE SAP
8860873200

CODICE EAN
8690842129551

CARATTERISTICHE PRINCIPALI

- Acciaio Inox
- Comandi frontali
- Anteriore centrale: 1 kW
- Anteriore destro: 1,75 kW
- Posteriore centrale: 1,75 kW
- Posteriore destro: 2,9 kW
- Sinistro: High Power 5 kW
- Trattamento PractiClean®
- Accensione elettronica integrata
- Uso di gas naturale G20-20 mbar
- Adattabile a GPL G30-30 mbar
- Dispositivo di sicurezza per assenza di fiamma
- Potenza: 12,4 kW

Cod. LUBE
075083Q4D

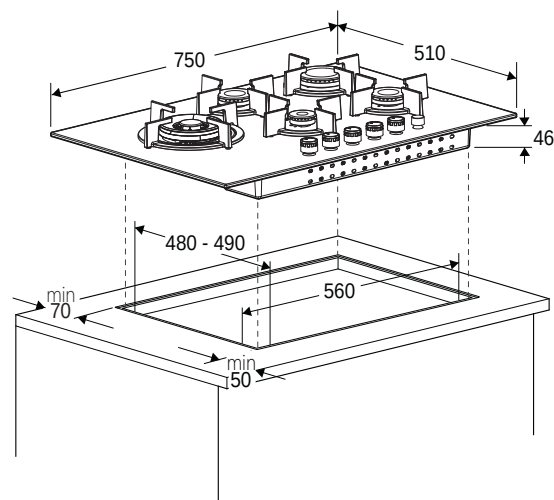

CODICE SAP
7751688394

CODICE EAN
8690842526619

HIAW75226SXE RCBMA17400KSEMP5

Piano cottura a gas

75 cm



Griglie in ghisa



Doppia corona
5 kW



High efficiency
burner



FlameAdjust

HIAL75224SXE

Piano cottura a gas

75 cm



Doppia corona



High efficiency
burner

CARATTERISTICHE PRINCIPALI

- Acciaio Inox
- Comandi frontali
- Anteriore sinistro: 1 kW
- Anteriore destro: 1,75 kW
- Posteriore sinistro: 2,9 kW
- Posteriore destro: 1,75 kW
- Centrale: High Power 5 kW
- Trattamento PractiClean®
- Accensione elettronica integrata
- Uso di gas naturale G20-20 mbar
- Adattabile a GPL G30-30 mbar
- Dispositivo di sicurezza per assenza di fiamma
- Potenza: 12,4 kW

Cod. LUBE

075083Q4C

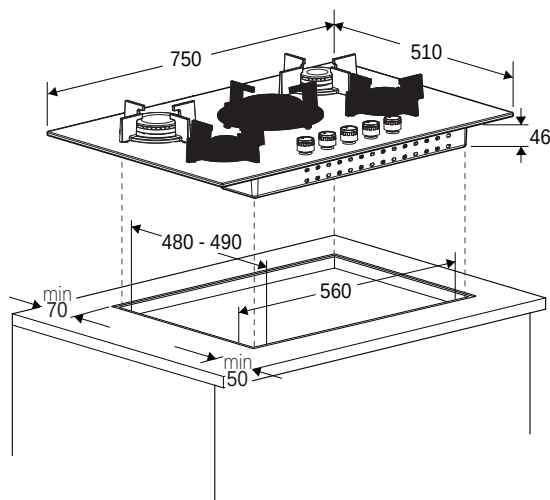

CARATTERISTICHE PRINCIPALI

- Acciaio Inox
- Comandi frontali
- Anteriore centrale: 1 kW
- Anteriore destro: 1,75 kW
- Posteriore centrale: 1,75 kW
- Posteriore destro: 2,9 kW
- Sinistro: Wok 3,3 kW
- Trattamento PractiClean®
- Griglie smaltate
- Accensione elettronica integrata
- Uso di gas naturale G20-20 mbar
- Adattabile a GPL G30-30 mbar
- Dispositivo di sicurezza per assenza di fiamma
- Potenza: 10,7 kW

Cod. LUBE

075084Q44

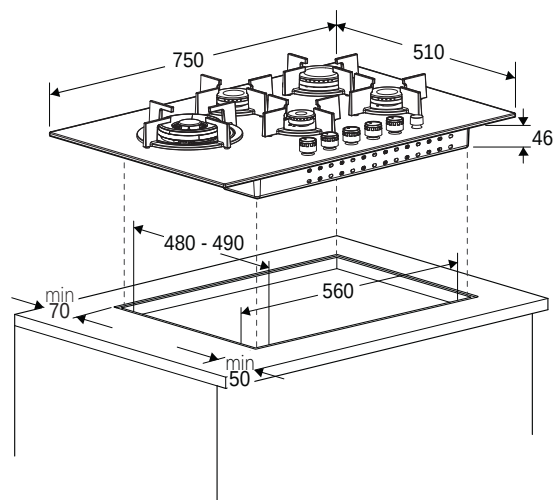

CODICE SAP
7751688395

CODICE EAN
8690842526602

CODICE SAP
7751688396

CODICE EAN
8690842526596

HIAW75224SXE
RCBMA17400KSEMP5

Piano cottura a gas

75 cm



HIAW64226SXE

Piano cottura a gas

60 cm



Doppia corona



High efficiency burner



Griglie in ghisa



Doppia corona



High efficiency burner



FlameAdjust

CARATTERISTICHE PRINCIPALI

- Acciaio Inox
- Comandi frontali
- Anteriore sinistro: 1 kW
- Anteriore destro: 1,75 kW
- Posteriore sinistro: 2,9 kW
- Posteriore destro: 1,75 kW
- Centrale: 3,3 kW
- Trattamento PractiClean®
- Griglie smaltate
- Accensione elettronica integrata
- Uso di gas naturale G20-20 mbar
- Adattabile a GPL G30-30 mbar
- Dispositivo di sicurezza per assenza di fiamma
- Potenza: 10,7 kW

Cod. LUBE

075084Q42

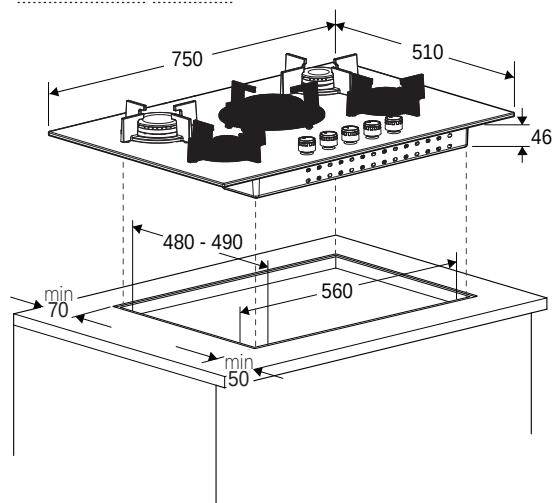

CARATTERISTICHE PRINCIPALI

- Acciaio Inox
- Comandi frontali
- Anteriore sinistro: 3,3 kW
- Anteriore destro: 1 kW
- Posteriore sinistro: 1,75 kW
- Posteriore destro: 1,75 kW
- Trattamento PractiClean®
- Accensione elettronica integrata
- Uso di gas naturale G20-20 mbar
- Adattabile a GPL G30-30 mbar
- Potenza: 7,8 kW

Cod. LUBE

075067Q33

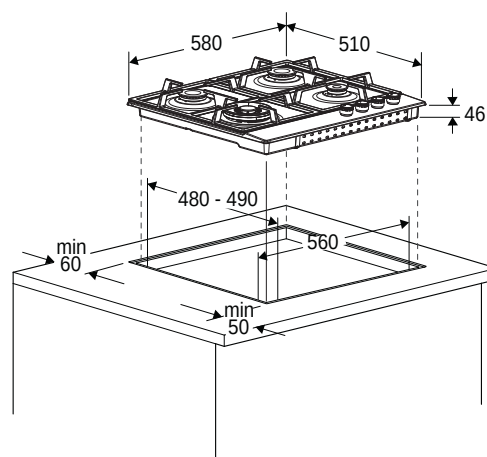

CODICE SAP
7751688397

CODICE EAN
8690842526589

CODICE SAP
7751688391

CODICE EAN
8690842526527

HIAG64224SXE

Piano cottura a gas

60 cm**HIAG64224SXE**

Piano cottura a gas

60 cm

Doppia corona

High efficiency
burnerHigh efficiency
burner**CARATTERISTICHE PRINCIPALI**

- Acciaio Inox
- Comandi frontali
- Anteriore sinistro: 3,3 kW
- Anteriore destro: 1 kW
- Posteriore sinistro: 1,75 kW
- Posteriore destro: 1,75 kW
- Centrale: High Power 5 kW
- Trattamento PractiClean®
- Griglie smaltate
- Accensione elettronica integrata
- Uso di gas naturale G20-20 mbar
- Adattabile a GPL G30-30 mbar
- Dispositivo di sicurezza per assenza di fiamma
- Potenza: 7,8 kW

Cod. LUBE

075065Q26

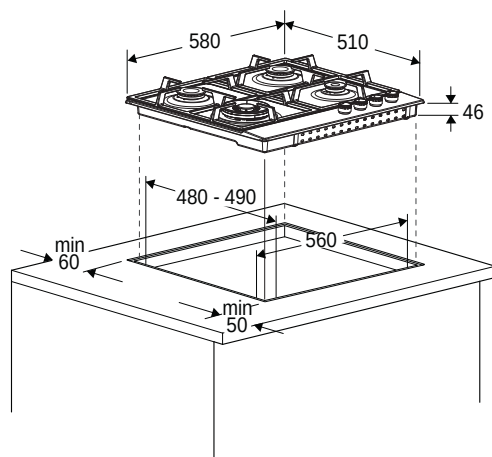
**CARATTERISTICHE PRINCIPALI**

- Acciaio Inox
- Comandi frontali
- Anteriore sinistro: 1,75 kW
- Anteriore destro: 1 kW
- Posteriore sinistro: 2,9 kW
- Posteriore destro: 1,75 kW
- Trattamento PractiClean®
- Griglie smaltate
- Accensione elettronica integrata
- Uso di gas naturale G20-20 mbar
- Adattabile a GPL G30-30 mbar
- Dispositivo di sicurezza per assenza di fiamma
- Potenza: 7,4 kW

Cod. LUBE

075065Q32

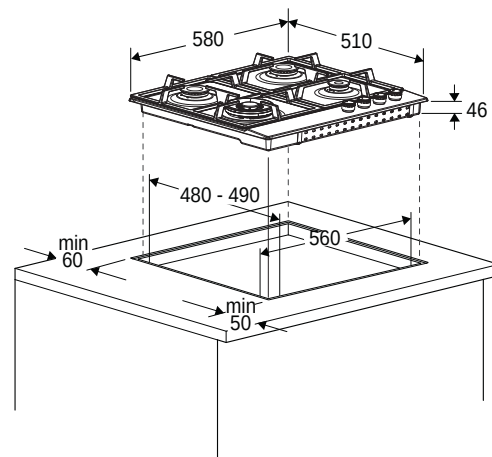
**CODICE SAP**
7750188371**CODICE EAN**
8690842526510**CODICE SAP**
7751688398**CODICE EAN**
8690842526565



Cod. LUBE
075065Q54

8690842399541

HIGG64123SB

Piano cottura a gas

60 cm



HIGG64123SW RCBEMFA174100XSBMPS

Piano cottura a gas

60 cm



CARATTERISTICHE PRINCIPALI

- Finitura nera
- Comandi laterali
- Anteriore sinistro: 2,9 kW
- Anteriore destro: 1 kW
- Posteriore sinistro: 2 kW
- Posteriore destro: 2 kW
- Griglie smaltate
- Accensione elettronica integrata
- Uso di gas naturale G20-20 mbar
- Adattabile a GPL G30-30 mbar
- Dispositivo di sicurezza per assenza di fiamma
- Potenza: 7,8 kW

Cod. LUBE

075165Q56

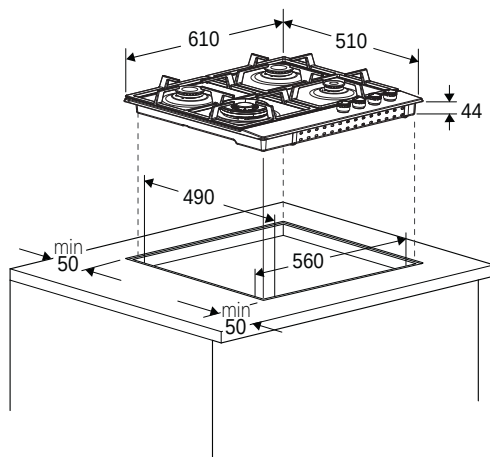

CARATTERISTICHE PRINCIPALI

- Finitura bianca
- Comandi laterali
- Anteriore sinistro: 2,9 kW
- Anteriore destro: 1 kW
- Posteriore sinistro: 2 kW
- Posteriore destro: 2 kW
- Griglie smaltate
- Accensione elettronica integrata
- Uso di gas naturale G20-20 mbar
- Adattabile a GPL G30-30 mbar
- Dispositivo di sicurezza per assenza di fiamma
- Potenza: 7,8 kW

Cod. LUBE

075165Q57

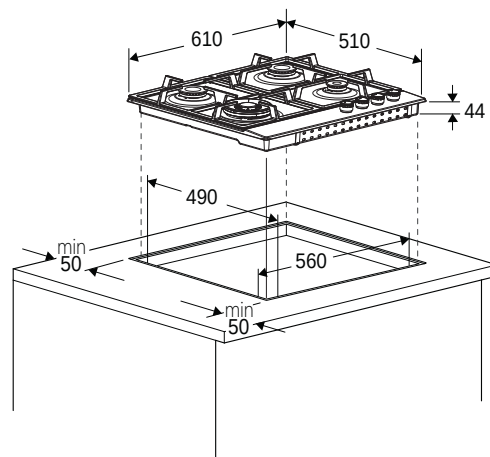

CODICE SAP
7754788376

CODICE EAN
8690842399473

CODICE SAP
7769987612

CODICE EAN
8690842399527

HIGM64123SX

Piano cottura misto

60 cm



HIGE64100X
RCRIMA F200KSRMPS

Piano cottura elettrico

60 cm



CARATTERISTICHE PRINCIPALI

- Acciaio Inox
- Comandi laterali
- Anteriore sinistro: 2,9 kW
- Anteriore destro: 1 kW
- Posteriore sinistro (piastra elettrica): Ø145mm – 1 kW
- Posteriore destro: 2 Kw
- Griglie smaltate
- Accensione elettronica integrata
- Uso di gas naturale G20-20 mbar
- Adattabile a GPL G30-30 mbar
- Dispositivo di sicurezza per assenza di fiamma
- Potenza: 5,9 kW
- Potenza elettrica: 1 kW

Cod. LUBE

075064Q66

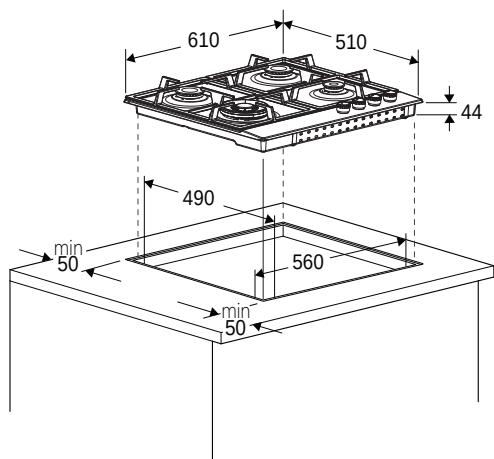

CARATTERISTICHE PRINCIPALI

- Acciaio Inox
- Comandi laterali
- Anteriore sinistro: Ø180mm – 1,5 kW
- Anteriore destro: Ø145mm – 1 kW
- Posteriore sinistro: Ø145mm – 1 kW
- Posteriore destro: Ø180mm – 1,5 kW
- 4 zone di cottura
- 6 livelli di cottura
- Potenza elettrica: 6 kW

Cod. LUBE

075062Q60

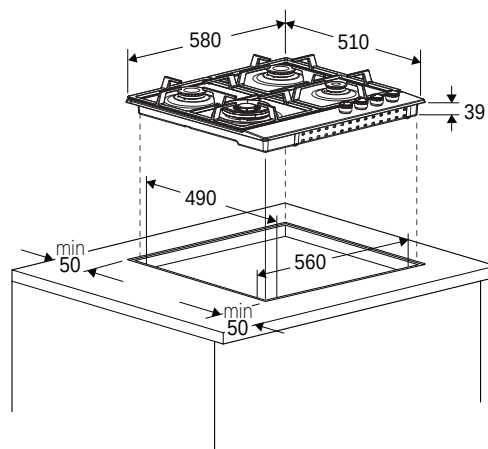

CODICE SAP
7768588357

CODICE EAN
8690842399503

CODICE SAP
7768687652

CODICE EAN
8690842535031

HIAW75224SAVR

Piano cottura a gas

75 cm



HIAW75224SAR

Piano cottura a gas

75 cm



Doppia corona
5 kW



High efficiency
burner



Doppia corona
5 kW



High efficiency
burner

CARATTERISTICHE PRINCIPALI

- Finitura avena
- Comandi frontali
- Anteriore sinistro: 1 kW
- Anteriore destro: 1,75 kW
- Posteriore sinistro: 2,9 kW
- Posteriore destro: 1,75 kW
- Centrale: 5 kW
- Griglie smaltate
- Accensione elettronica integrata
- Uso di gas naturale G20-20 mbar
- Adattabile a GPL G30-30 mbar
- Dispositivo di sicurezza per assenza di fiamma
- Potenza: 12,4 kW

Cod. LUBE

075182Q73

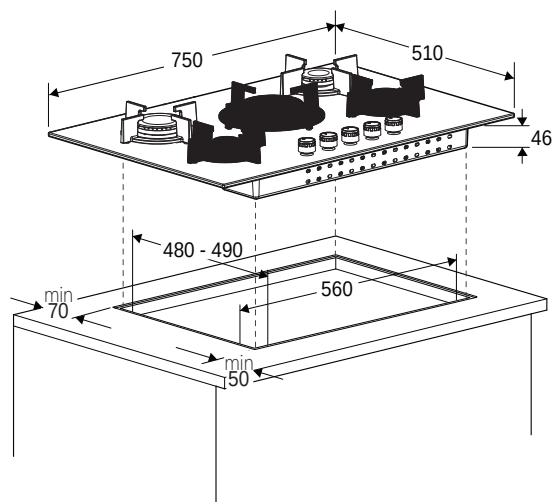

CODICE SAP
7751688330

CODICE EAN
8690842685460

CARATTERISTICHE PRINCIPALI

- Finitura antracite
- Comandi frontali
- Anteriore sinistro: 1 kW
- Anteriore destro: 1,75 kW
- Posteriore sinistro: 2,9 kW
- Posteriore destro: 1,75 kW
- Centrale: 5 kW
- Griglie smaltate
- Accensione elettronica integrata
- Uso di gas naturale G20-20 mbar
- Adattabile a GPL G30-30 mbar
- Dispositivo di sicurezza per assenza di fiamma
- Potenza: 12,4 kW

Cod. LUBE

075182Q74

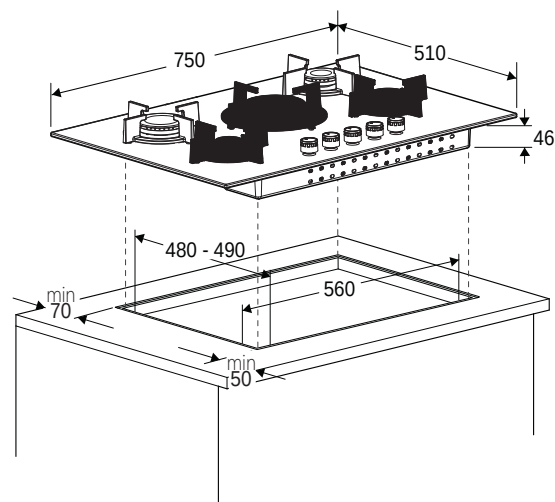

CODICE SAP
7751688339

CODICE EAN
8690842685453

HIAG64224SAVR

Piano cottura a gas

60 cm



HIAG64224SAR
BCRM17200K3BMPS

Piano cottura a gas

60 cm



High efficiency burner



High efficiency burner

CARATTERISTICHE PRINCIPALI

- Finitura avana
- Comandi frontali
- Anteriore sinistro: 1,75 kW
- Anteriore destro: 1 kW
- Posteriore sinistro: 2,9 kW
- Posteriore destro: 1,75 kW
- Griglie smaltate
- Accensione elettronica integrata
- Uso di gas naturale G20-20 mbar
- Adattabile a GPL G30-30 mbar
- Potenza: 7,4 kW

Cod. LUBE

075165Q70

CARATTERISTICHE PRINCIPALI

- Finitura antracite
- Comandi frontali
- Anteriore sinistro: 1,75 kW
- Anteriore destro: 1 kW
- Posteriore sinistro: 2,9 kW
- Posteriore destro: 1,75 kW
- Griglie smaltate
- Accensione elettronica integrata
- Uso di gas naturale G20-20 mbar
- Adattabile a GPL G30-30 mbar
- Potenza: 7,4 kW

Cod. LUBE

075165Q71

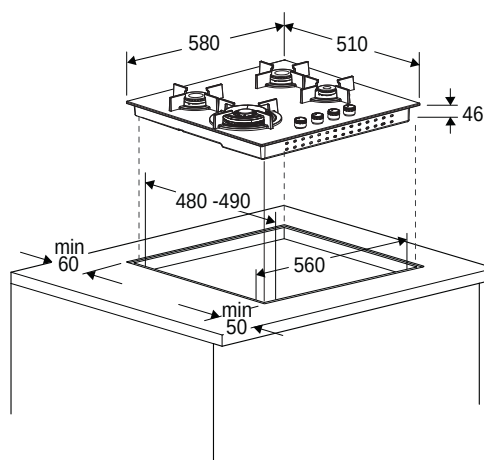
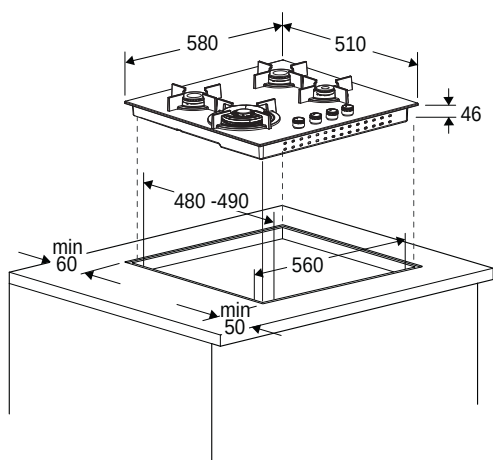

CODICE SAP
7751688329

CODICE EAN
8690842685446

CODICE SAP
7751688328

CODICE EAN
8690842685491

HDMI32400DT

Piano cottura a induzione

30 cm



HDC32200X

Piano cottura in vetroceramica

30 cm



Booster

CARATTERISTICHE PRINCIPALI

- Nero
- Comandi Touch control
- 9 livelli di cottura
- Anteriore: Ø160mm – 1,4 kW
- Posteriore: Ø200mm – 2,3/3,0 kW
- Riconoscimento automatico di pentole e padelle
- Dispositivo sicurezza bambini
- Indicatore calore residuo
- Sicurezza extraflusso
- Spegnimento automatico
- Potenza: 3,6 kW

Cod. LUBE

0749702

Da installare esclusivamente su basi predisposte per PC ad induzione.

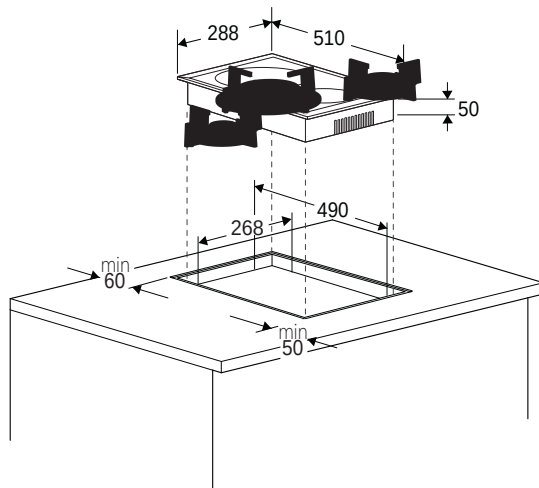

CODICE SAP
7787087601

CODICE EAN
8690842030758

CARATTERISTICHE PRINCIPALI

- Cornice inox
- Comandi frontali
- Anteriore: Ø140mm – 1,2 KW
- Posteriore: Ø180mm – 1,7 KW
- Potenza: 2,9 kW

Cod. LUBE

0749705

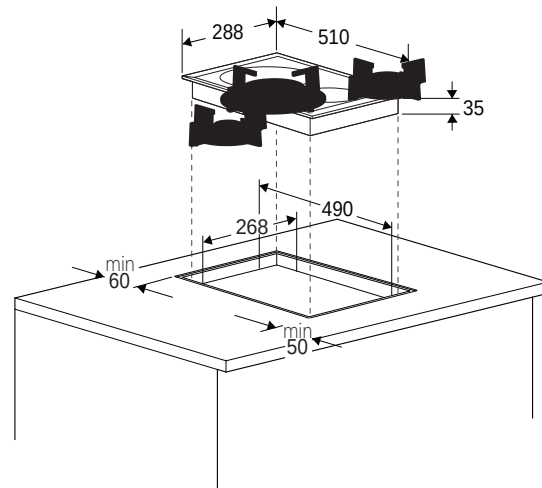

CODICE SAP
7724020201

CODICE EAN
8690842347573

HDCE32201X

Piano cottura elettrico

30 cm



HDGG32320EX

Piano cottura a gas

30 cm



CARATTERISTICHE PRINCIPALI

- Comandi frontali
- Anteriore: Ø145mm – 1,5 KW
- Posteriore: Ø180mm – 2 KW
- 6 livelli di cottura
- Potenza: 3,5 kW

Cod. LUBE
0749707

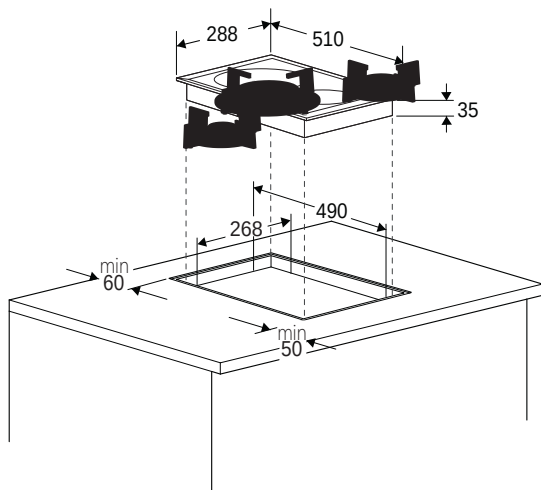

CODICE SAP
7724086001

CODICE EAN
8690842347610

CARATTERISTICHE PRINCIPALI

- Comandi frontali
- Anteriore: 1 kW
- Posteriore: 2,9 kW
- Griglie smaltate
- Accensione elettronica integrata
- Uso di gas naturale G20-20 mbar
- Adattabile a GPL G30-30 mbar
- Dispositivo di sicurezza per assenza di fiamma
- Potenza: 3,9 kW

Cod. LUBE
0749703

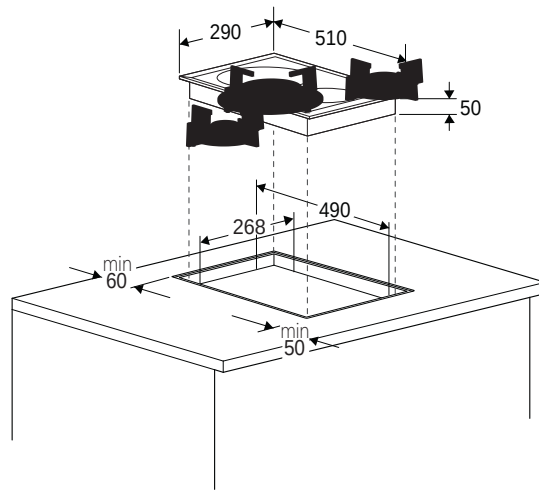

CODICE SAP
7725588304

CODICE EAN
8690842347955

SCHEMA DA INCASSO PER PIANI COTTURA DOMINO MONTATI IN SEQUENZA

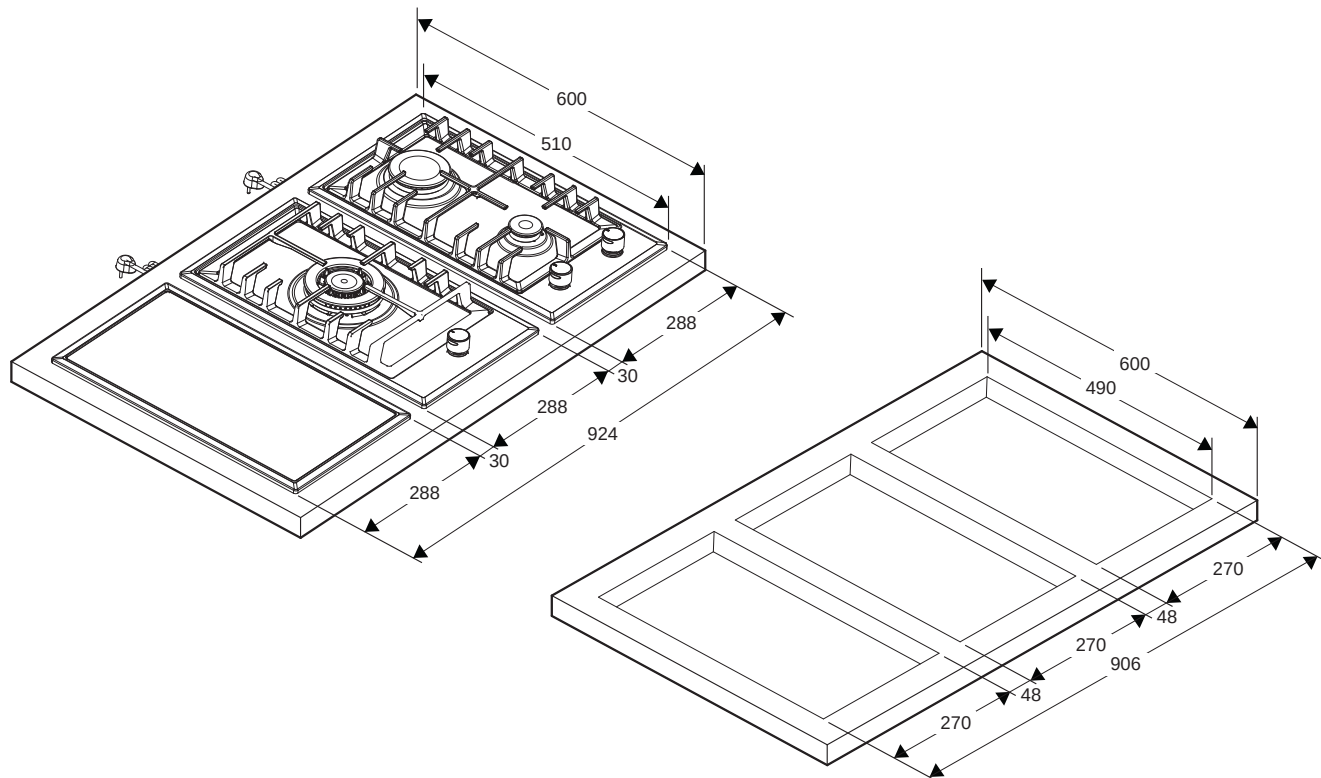

SOLUZIONI BRILLANTI PER LAVAGGI IMPECCABILI.

La lavastoviglie Beko unisce efficienza energetica a ottime prestazioni di lavaggio, rispondendo in modo completo alle esigenze di sostenibilità e pulizia avanzata. Il nostro impatto sulla sostenibilità ambientale è legato a specifiche tecnologie. Grazie alla **tecnologia AutoDose**, infatti, dosando automaticamente detergente e brillantante in base al tipo di lavaggio, vengono ridotti gli sprechi e si contribuisce a diminuire l'inquinamento delle acque. Inoltre, la classe energetica A assicura una notevole riduzione dei consumi, mentre il **sistema EcoFocus** ottimizza il processo di asciugatura **risparmiando fino al 25% di energia**: il calore viene concentrato direttamente sulla superficie delle stoviglie, evitando dispersioni all'interno del cestello. A completare l'attenzione al risparmio, **la funzione SelfDry® facilita la circolazione** dell'aria grazie all'apertura automatica della porta al termine del ciclo, migliorando le prestazioni di asciugatura fino a triplicarle rispetto ai sistemi tradizionali.

Sul fronte delle performance di lavaggio, l'irroratore rotante a tre bracci **CornerIntense™ garantisce una pulizia** profonda raggiungendo ogni angolo del cestello, eliminando la necessità di prelavaggi anche per pentole e stoviglie molto sporche. La **tecnologia DeepWash** è invece studiata appositamente per assicurare un trattamento intensivo a bottiglie, biberon, caraffe e bicchieri lunghi, offrendo risultati impeccabili anche per gli oggetti più difficili da trattare. **Questa combinazione di innovazioni rende la lavastoviglie Beko la scelta ideale per chi desidera coniugare sostenibilità ambientale e prestazioni avanzate, adattandosi a qualsiasi esigenza di lavaggio.**



04

**FAI LA SCELTA GIUSTA,
SCEGLI LA FLESSIBILITÀ.**

METODI DI INSTALLAZIONE

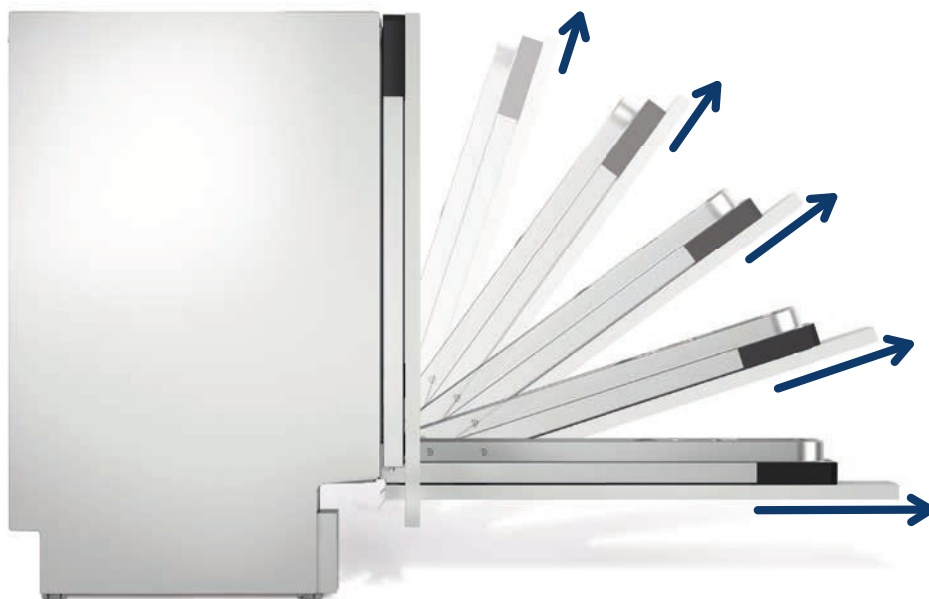

SLIDEFIT+

Il sistema Slidefit+ consente l'utilizzo di ante di lunghezza superiore, fino a 80 cm, garantendo un adattamento ottimale in fase di apertura e chiusura. Questa tecnologia avanzata permette inoltre di ridurre l'altezza dello zoccolo fino a 0 cm, assicurando un'integrazione perfetta dell'elettrodomestico nelle cucine con linee minimaliste e senza spazi vuoti alla base. Tale configurazione non solo migliora l'estetica della cucina, ma ottimizza anche lo sfruttamento dello spazio disponibile, offrendo maggiore libertà progettuale.



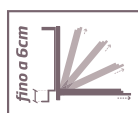

SLIDEFIT

L'innovativo sistema di scorrimento dell'anta consente al pannello frontale di muoversi sopra la porta della lavastoviglie durante l'apertura. Questa soluzione meccanica avanzata permette di minimizzare lo spazio necessario sotto l'apparecchio, riducendo l'altezza dello zoccolo fino a soli 6 cm. In questo modo si ottiene una maggiore flessibilità, favorendo l'integrazione del modulo in cucine con zoccoli di altezza ridotta senza compromettere la stabilità o l'estetica complessiva della composizione.



LAVASTOVIGLIE CON CERNIERE RINFORZATE 9-12 KG

La soluzione ideale per cucine da 75 cm

Scopri la nuova generazione di lavastoviglie con cerniere rinforzate, ideali per chi cerca affidabilità, durata e adattabilità. Questo modello innovativo è progettato per supportare anche le ante più pesanti dai 9 ai 12kg, con un design strutturato per integrarsi perfettamente in cucine con moduli di larghezza da 75 cm, ampliando le possibilità di gestione dei tuoi spazi.

BDIN38562C

Lavastoviglie a **scomparsa totale**
da **60 cm** con anta 9-12kg



BDIN386E4AD

Lavastoviglie a **scomparsa totale**
da **60 cm**



SlideFit 9-12 kg



Tecnologia CornerIntense™



Apertura porta automatica SelfDry®



Motore ProSmart™ Inverter



Autodose



SlideFit+



Illuminazione interna



Motore ProSmart™ Inverter

CARATTERISTICHE PRINCIPALI

- 15 coperti
- 8 programmi e 5 temperature di lavaggio
- Terzo cestello
- Partenza ritardata fino a 24h
- Consumo di acqua: 9,9 L
- Rumorosità: 42 dBA

Cod. LUBE

0 7 7 5 4 0 Q 6 9

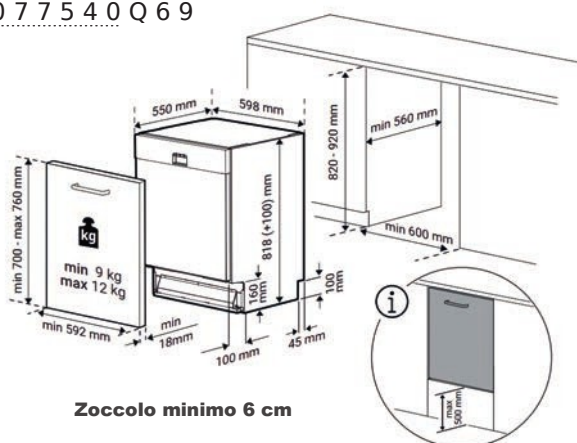

Zoccolo minimo 6 cm

CARATTERISTICHE PRINCIPALI

- 16 coperti
- 8 programmi e 5 temperature di lavaggio
- Terzo cestello
- Tecnologia CornerIntense™
- DeepWash
- Consumo di acqua: 9,5 L
- Rumorosità: 40 dBA

Cod. LUBE

0 7 7 5 4 0 Q 6 3

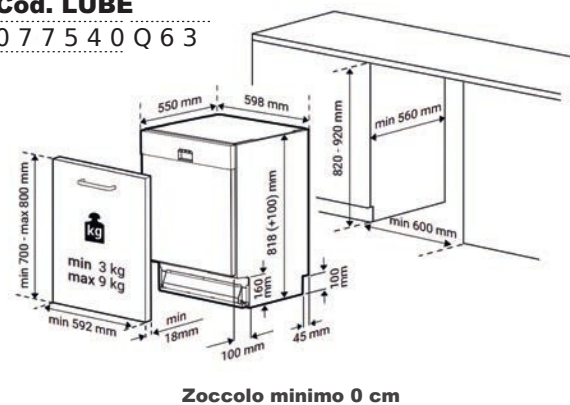

Zoccolo minimo 0 cm

N.b. Non inseribile con ante estetica 2 cestoni modulistica h 84

CODICE SAP
7604792077

CODICE EAN
8690842657702

CODICE SAP
7658304177

CODICE EAN
8690842509735

BDIN38561CLavastoviglie a **scomparsa totale**
da **60 cm****BDIN38645D**Lavastoviglie a **scomparsa totale**
da **60 cm**

SlideFit

Tecnologia
CornerIntense™Apertura porta
automatica
SelfDry®Motore
ProSmart™
Inverter

SlideFit

Illuminazione
interna

DeepWash

Motore
ProSmart™
Inverter**CARATTERISTICHE PRINCIPALI**

- 15 coperti
- 8 programmi e 5 temperature di lavaggio
- Terzo cestello
- Tecnologia CornerIntense™
- Partenza ritardata fino a 24h
- Consumo di acqua: 9,9 L
- Rumorosità: 42 dBA

Cod. LUBE

0 7 7 5 4 0 Q 6 4

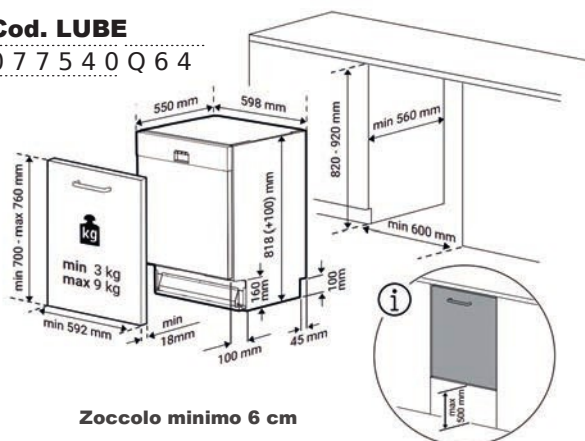
**Zoccolo minimo 6 cm****CARATTERISTICHE PRINCIPALI**

- 16 coperti
- 8 programmi e 5 temperature di lavaggio
- Terzo cestello
- Tecnologia CornerIntense™
- Consumo di acqua: 9,5 L
- Rumorosità: 42 dBA

Cod. LUBE

0 7 7 5 4 0 Q 6 2

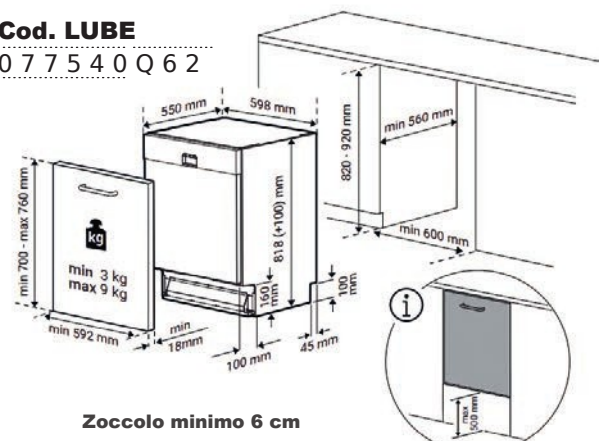
**Zoccolo minimo 6 cm**

N.b. Non inseribile con ante estetica 2 cestoni modulistica h 84

N.b. Non inseribile con ante estetica 2 cestoni modulistica h 84

CODICE SAP
7697002077**CODICE EAN**
8690842638466**CODICE SAP**
7628502677**CODICE EAN**
8690842466847

BDIN36532

Lavastoviglie a **scomparsa totale**
da **60 cm**



BDIN36530

Lavastoviglie a **scomparsa totale**
da **60 cm**



SlideFit+



Apertura porta
automatica
SelfDry®



SlideFit



Apertura porta
automatica
SelfDry®

CARATTERISTICHE PRINCIPALI

- 15 coperti
- 6 programmi e 5 temperature di lavaggio
- Terzo cestello flessibile
- Partenza ritardata fino a 24h
- Consumo di acqua: 9,9 L
- Rumorosità: 45 dBA

Cod. LUBE

0 7 7 5 4 0 Q 6 5

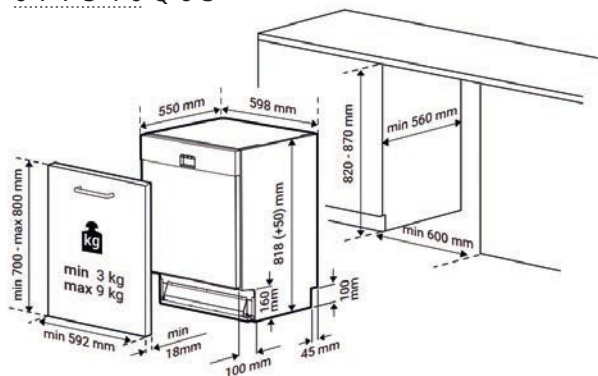

Zoccolo minimo 0 cm

CARATTERISTICHE PRINCIPALI

- 15 coperti
- 6 programmi e 5 temperature di lavaggio
- Terzo cestello
- Partenza ritardata fino a 24h
- Consumo di acqua: 9,9 L
- Rumorosità: 45 dBA

Cod. LUBE

0 7 7 5 4 0 Q 6 6

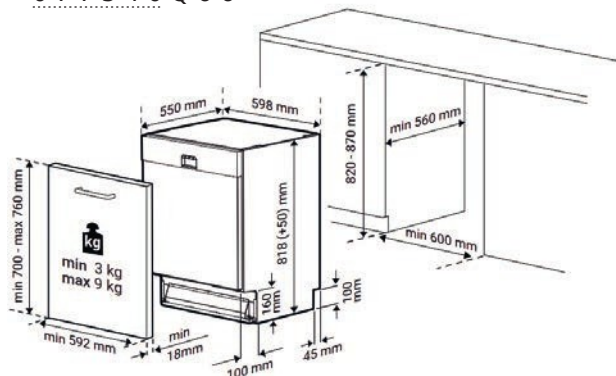

Zoccolo minimo 6 cm

N.b. Non inseribile con ante estetica 2 cestoni modulistica h 84

N.b. Non inseribile con ante estetica 2 cestoni modulistica h 84

CODICE SAP
7692903977

CODICE EAN
8690842623394

CODICE SAP
7675503977

CODICE EAN
8690842565731

DIN35321Lavastoviglie a **scomparsa totale**
da **60 cm****BDIN25320**Lavastoviglie a **scomparsa totale**
da **60 cm**

SlideFit

Apertura porta
automatica
SelfDry®**CARATTERISTICHE PRINCIPALI**

- 13 coperti
- 5 programmi e 4 temperature di lavaggio
- Cestello portaposate scorrevole
- Funzione mezzo carico
- Consumo di acqua: 12,9 L
- Rumorosità: 49 dBA

Cod. LUBE

0 7 7 5 4 0 Q 4 2

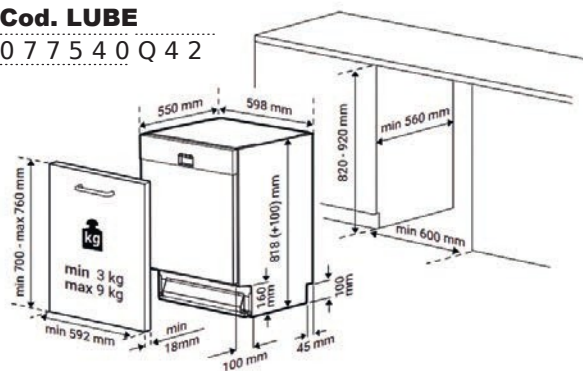
**Zoccolo minimo 6 cm**

N.b. Non inseribile con ante estetica 2 cestoni modulistica h 84

CODICE SAP
7683963977**CODICE EAN**
8690842258121**CARATTERISTICHE PRINCIPALI**

- 13 coperti
- 5 programmi e 4 temperature di lavaggio
- Cestello portaposate standard
- Funzione mezzo carico
- Consumo di acqua: 12,9 L
- Rumorosità: 49 dBA

Cod. LUBE

0 7 7 5 4 0 Q 6 7

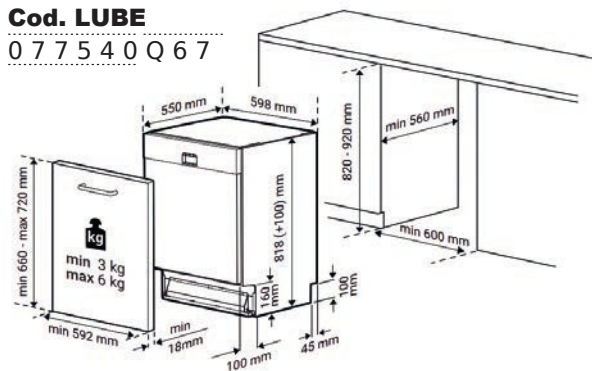
**CODICE SAP**
7693902077**CODICE EAN**
8690842628085

N.b. Non inseribile con ante estetica 2 cestoni modulistica h 84

BDSN15422X

Lavastoviglie **semi-integrata**
da **60 cm**



DIS35020

Lavastoviglie **slim**
da **45 cm**



Apertura porta
automatica
SelfDry®

CARATTERISTICHE PRINCIPALI

- 14 coperti
- 5 programmi e 4 temperature di lavaggio
- Cruscotto Acciaio Inox
- Partenza ritardata 3/6/9 h
- Consumo di acqua: 11,5 L
- Rumorosità: 48 dBA

Cod. LUBE

0 7 7 5 4 0 Q 7 0

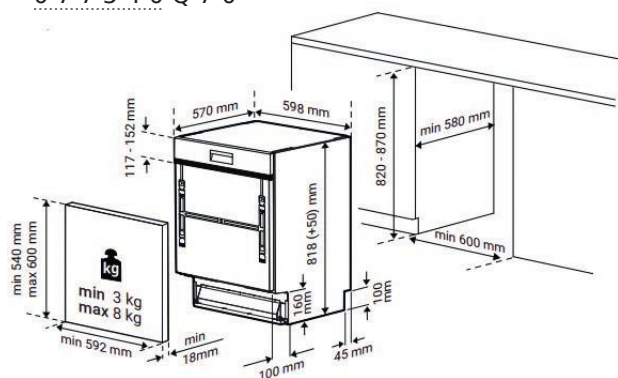

CARATTERISTICHE PRINCIPALI

- 10 coperti
- 5 programmi e 5 temperature di lavaggio
- Funzione mezzo carico
- Consumo di acqua: 11,9 L
- Rumorosità: 49 dBA

Cod. LUBE

0 7 7 5 3 3 Q 1 5

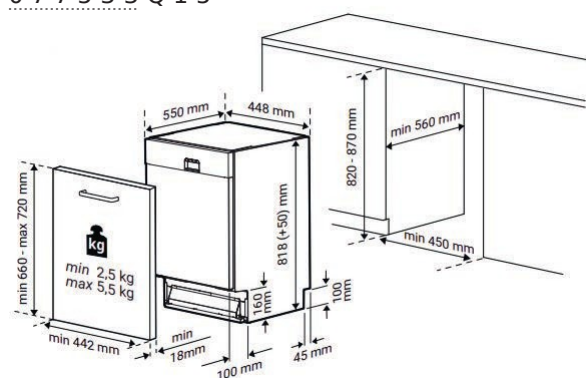

N.b. Non inseribile con ante estetica 2 cestoni modulistica h 84

CODICE SAP
7684001077

CODICE EAN
8690842576416

CODICE SAP
7680253935

CODICE EAN
8690842391835



NUTRI IL TUO BENESSERE CON IL FRIGORIFERO **MONTEBIANCO 75.**

Un frigorifero non è solo un elettrodomestico, è il cuore della tua cucina e il custode del tuo benessere. Con Beko Montebianco 75, ogni alimento è trattato con la massima cura, conservando intatte le sue proprietà nutritive.

Immagina frutta e verdura che mantengono il loro sapore e il loro colore più a lungo, grazie alla tecnologia HarvestFresh® che simula il ciclo naturale del sole. Ma non solo, grazie al sistema AeroFlow® e al doppio circuito di raffreddamento, si mantengono le temperature ideali sia nel frigo che nel freezer, prevenendo la formazione di ghiaccio e la contaminazione degli odori.

Scegli Beko Montebianco 75 e fai una scelta consapevole per te e per l'ambiente.

Perché quando i tuoi alimenti stanno bene, stai bene anche tu.



05

**FAI LA SCELTA GIUSTA,
SCEGLI IL BENESSERE.**



MONTEBIANCO 75

Immagina di avere uno **spazio infinito per conservare tutti i tuoi alimenti freschi.**

Con Beko Montebianco 75, è come avere un intero carrello della spesa sempre a portata di mano.

Fino a **400 litri di capacità** ti permettono di organizzare al meglio la tua cucina e di dire addio agli sprechi alimentari.

Design innovativo e tecnologie avanzate si uniscono per offrirti la massima praticità e funzionalità.

45% di spazio in più*



**FINO A 400 LITRI DI CAPACITÀ,
UNA MIGLIORE GESTIONE
DELLO SPAZIO INTERNO
E UNA CONSERVAZIONE DEI CIBI
FINO A 3 VOLTE PIÙ A LUNGO.**

*Rispetto a un combinato standard 177x54 cm



BCNE400E40MSN

Frigorifero **combinato h 193x69 cm**
con **tecnologia AeroFlow®**



45%
di spazio in
rispetto a un combinato
standard 177x54 cm



Total No Frost



Aereoflow®



24H
HarvestFresh®



Compressore
ProSmart™ Inverter

CARATTERISTICHE PRINCIPALI

- Volume netto totale: 370 L (volume netto frigorifero: 280 L, volume netto freezer: 90 L)
- Parete posteriore in metallo
- Cassetto frutta e verdura e comparto alimenti freschi
- Display Touch
- Porte reversibili
- Cerniere scorrevoli

Cod. LUBE

0 7 7 0 5 6 Q 8 C

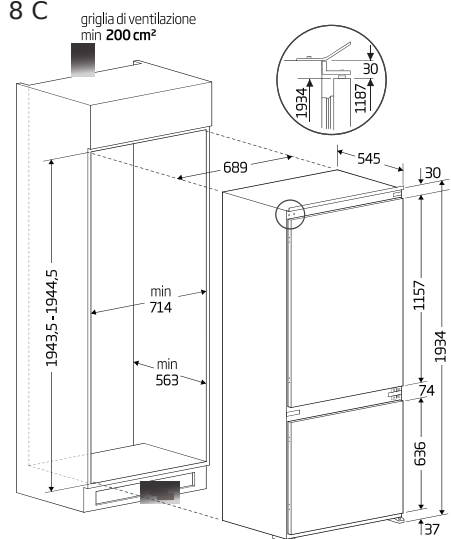

Disponibile
da Marzo 2025

CODICE SAP
7278743110

CODICE EAN
8690842658617

BCNE400E40SN

Frigorifero **combinato h 193x69 cm**
con **tecnologia AeroFlow®**



45% di spazio in più
Rispetto a un combinato standard 177x54 cm



BCSE400E40SN

Frigorifero **combinato h 193x69 cm**
statico con ventola



45% di spazio in più
Rispetto a un combinato standard 177x54 cm



Total No Frost



Aereoflow®



HarvestFresh®



Compressore ProSmart™ Inverter



Statico Ventilato



HarvestFresh®



Cassetto frutta e verdura



Compressore ProSmart™ Inverter

CARATTERISTICHE PRINCIPALI

- Volume netto totale: 370 L (volume netto frigorifero: 280 L, volume netto freezer: 90 L)
- Display Touch
- Cerniere scorrevoli
- Cassetto frutta e verdura e comparto alimenti freschi
- EverFresh+: per controllare l'umidità nel cassetto frutta e verdura
- Porte reversibili

Cod. LUBE

* 077056Q8E

Cod. LUBE

** 077056Q8F

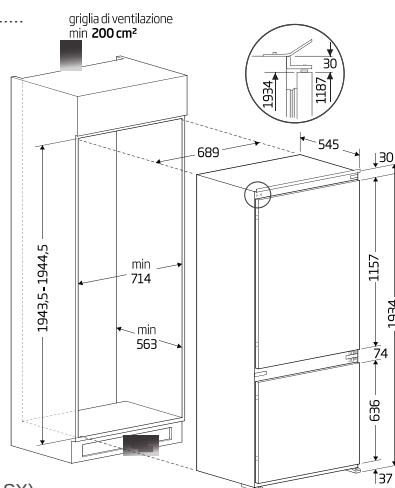

* BCNE400E40SN (ap. DX)
** BCNE400E40SN LH (ap. SX)

CODICE SAP

* 7278743103

** 7278743105

CODICE EAN

8690842418877

8690842419614

CARATTERISTICHE PRINCIPALI

- Volume netto totale: 400 L (volume netto frigorifero: 300 L, volume netto freezer: 100 L)
- Display Touch
- Cerniere scorrevoli
- Comparto alimenti freschi
- Porte reversibili

Cod. LUBE

* 077056Q8A

Cod. LUBE

** 077056Q8B

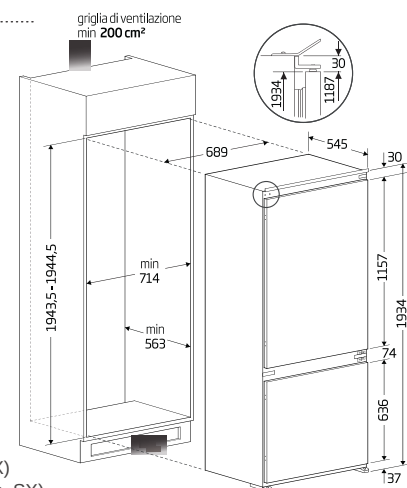

* BCNE400E40SN (ap. DX)
** BCSE400E40SN LH (ap. SX)

CODICE SAP

* 7278743101

** 7278743104

CODICE EAN

8690842409295

8690842419607

BCNA306E4SN

Frigorifero **combinato h 193 cm**
con **tecnologia NeoFrost™ Dual Cooling**



BCNA306E4SN BCNA17200KSBMPS

Frigorifero **combinato h 193 cm**
con **tecnologia No Frost**



Total No Frost



NeoFrost™
Dual Cooling



HarvestFresh®



Compressore
ProSmart™ Inverter



No Frost



HarvestFresh®



Comparto
alimenti freschi



Compressore
ProSmart™ Inverter

CARATTERISTICHE PRINCIPALI

- Volume netto totale: 284 L (volume netto frigorifero: 215 L, volume netto freezer: 69 L)
- Display Touch
- Cerniere scorrevoli
- Parete posteriore in metallo
- Cassetto frutta e verdura
- Comparto alimenti freschi
- Porte reversibili

Cod. LUBE

0 7 7 0 5 4 Q 6 1

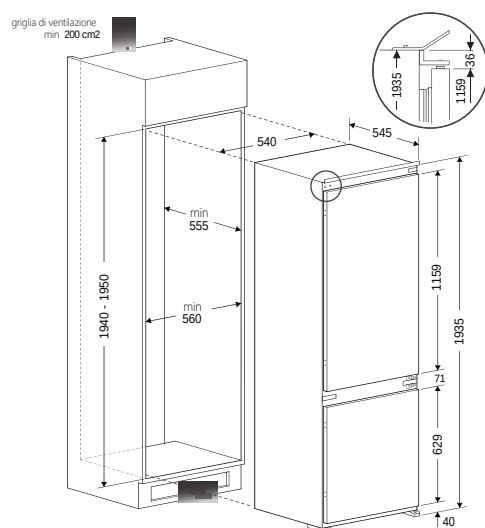

CODICE SAP
7523420012

CODICE EAN
5944008923266

CARATTERISTICHE PRINCIPALI

- Volume netto totale: 289 L (volume netto frigorifero: 220 L, volume netto freezer: 69 L)
- Display Touch
- Cerniere scorrevoli
- Reparto frigorifero: Statico
- Reparto Freezer: No Frost
- Cassetto frutta e verdura
- Porte reversibili

Cod. LUBE

0 7 7 0 5 4 Q 4 6

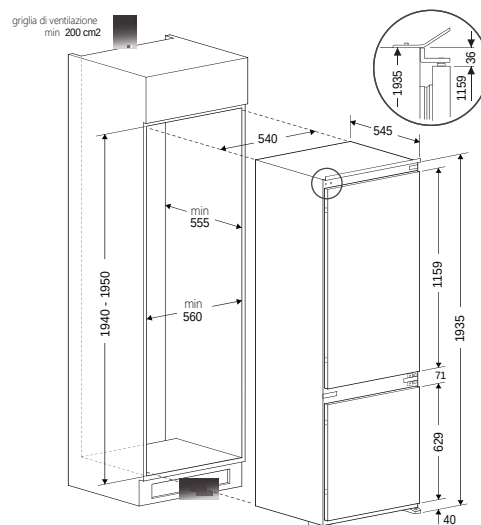

CODICE SAP
7523120010

CODICE EAN
8690842559228

BCSA306E4SFN

Frigorifero combinato h 193 cm
statico con ventola



Statico Ventilato



Cassetto frutta e
verdura



Comparto
alimenti freschi



Compressore
ProSmart™ Inverter

CARATTERISTICHE PRINCIPALI

- Volume netto totale: 298 L (volume netto frigorifero: 220 L, volume netto freezer: 78 L)
- Cerniere scorrevoli
- Porte reversibili
- Display Touch

Cod. LUBE

* 077054Q64

Cod. LUBE

** 077054Q65

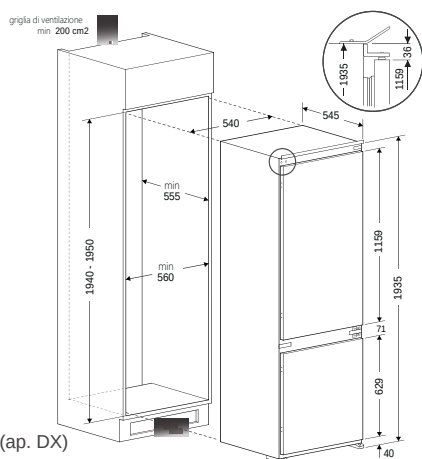

* BCSA306E4SFN (ap. DX)

** BCSA306E4SFN LH (ap. SX)

CODICE SAP

* 7523220010

** 7523220009

CODICE EAN

8690842371738

8690842371752



BCNA275E41SN
BCRMA17400KSBMPS

Frigorifero **combinato h 177 cm**
con **tecnologia NeoFrost™ Dual Cooling**



BCHA275E4SN

Frigorifero **combinato h 177 cm**
con **tecnologia No Frost**



Total No Frost



NeoFrost™
Dual Cooling



HarvestFresh®



Compressore
ProSmart™ Inverter



No Frost



HarvestFresh®



Comparto alimenti
freschi



Compressore
ProSmart™ Inverter

CARATTERISTICHE PRINCIPALI

- Volume netto totale: 254 L (volume netto frigorifero: 185 L, volume netto freezer: 69 L)
- Cassetto frutta e verdura
- Porte reversibili
- Display Touch
- Cerniere scorrevoli

Cod. LUBE

0 7 7 0 4 0 Q 5 9

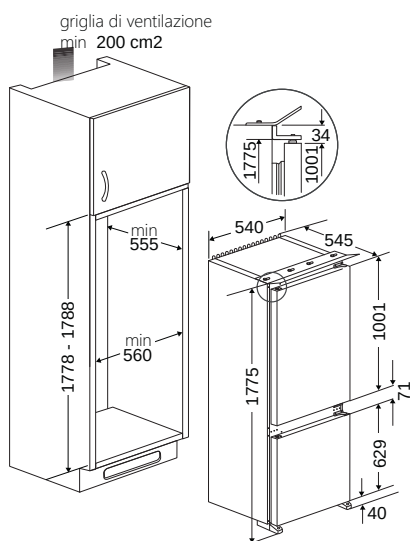

CODICE SAP
7523020045

CODICE EAN
8690842619809

CARATTERISTICHE PRINCIPALI

- Volume netto totale: 262 L (volume netto frigorifero: 193 L, volume netto freezer: 69 L)
- Reparto frigorifero: Statico
- Reparto Freezer: No Frost
- Cassetto frutta e verdura
- Display Touch
- Cerniere scorrevoli
- Porte reversibili

Cod. LUBE

0 7 7 0 4 0 Q 5 0

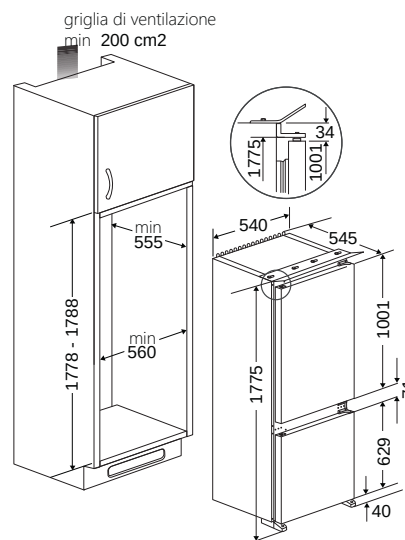

CODICE SAP
7520420023

CODICE EAN
5944008923228

BCSA285K4SFN

Frigorifero **combinato h 177 cm**
statico con ventola



Statico Ventilato



Cassetto frutta e
verdura



Compressore
ProSmart™ Inverter

CARATTERISTICHE PRINCIPALI

- Volume netto totale: 271 L (volume netto frigorifero: 193 L, volume netto freezer: 78 L)
- Cerniere scorrevoli
- Porte reversibili
- Controllo meccanico

Cod. LUBE

* 077040Q56

Cod. LUBE

** 077040Q57

griglia di ventilazione
min 200 cm²

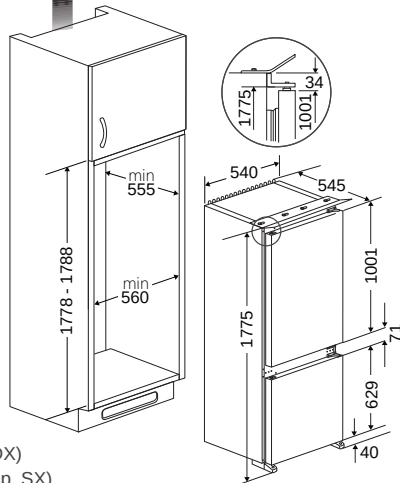

- * BCSA285K4SFN (ap. DX)
- ** BCSA285K4SFN LH (ap. SX)

CODICE SAP

* 7519020063

**7519020065

CODICE EAN

8690842619762

8690842624889

BCSA285K4SN

Frigorifero **combinato h 177 cm**
statico



Cassetto frutta e
verdura



Compressore
ProSmart™ Inverter

CARATTERISTICHE PRINCIPALI

- Volume netto totale: 271 L (volume netto frigorifero: 193 L, volume netto freezer: 78 L)
- Cerniere scorrevoli
- Porte reversibili
- Controllo meccanico

Cod. LUBE

* 077040Q38

Cod. LUBE

** 077040Q39

griglia di ventilazione
min 200 cm²

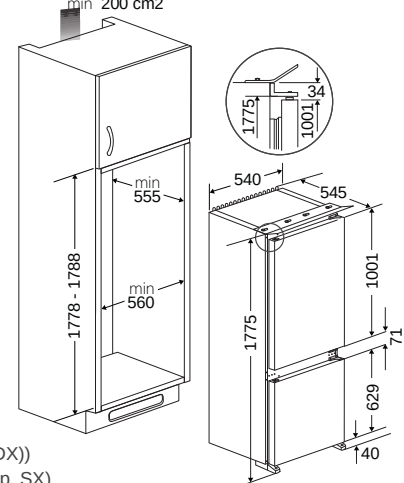

- * BCSA285K4SN (ap. DX)
- ** BCSA285K4SN LH (ap. SX)

CODICE SAP

* 7519020035

** 7519020064

CODICE EAN

8690842379376

8690842619823

BDSA250K4SN
BCRMA17200K4SNBMP5

Frigorifero **doppia porta h 145 cm**
statico



Cassetto frutta e verdura

CARATTERISTICHE PRINCIPALI

- Volume netto totale: 220 L (volume netto frigorifero: 176 L, volume netto freezer: 44 L)
- Cerniere scorrevoli
- Porte reversibili
- Controllo meccanico

Cod. LUBE

* 077025Q18

Cod. LUBE

** 077025Q19

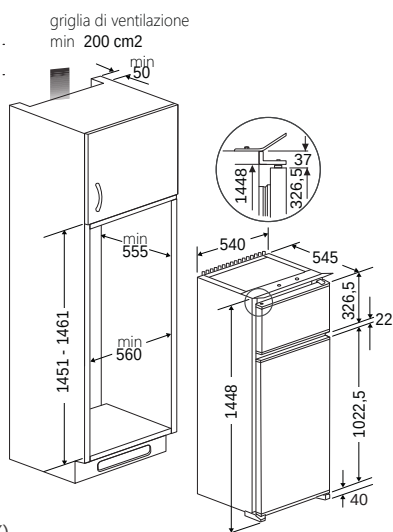

* BDSA250K4SN (ap. DX)
** BDSA250K4SN LH (ap. SX)

CODICE SAP

* 7521620017

** 7521620018

CODICE EAN

8690842620461

8690842620485



BSSA315E4SFN

Frigorifero **monoporta h 177 cm**
statico con ventola



RCBMA247E40SN BMA247E40SN BMA247E40SN BMA247E40SN

Congelatore **monoporta h 177 cm**
con tecnologia No Frost



Statico Ventilato



HarvestFresh®



Cassetto frutta e
verdura



Total No Frost



Compressore
ProSmart™ Inverter

CARATTERISTICHE PRINCIPALI

- Volume netto totale: 309 L
- 2 Cassetti frutta e verdura
- Display Touch
- Porte reversibili
- Cerniere scorrevoli

Cod. LUBE

077047Q91

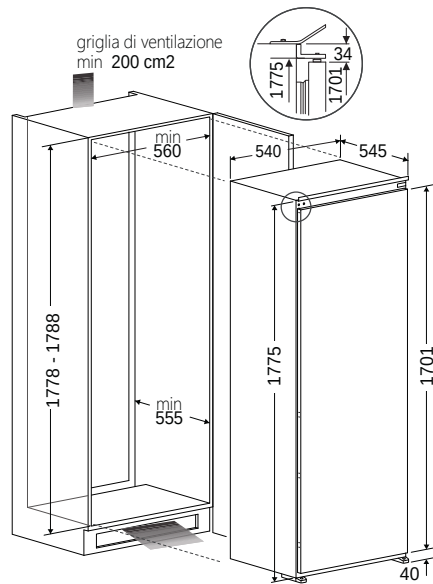

CARATTERISTICHE PRINCIPALI

- Volume netto totale: 220 L
- Cerniere scorrevoli
- Display Touch
- Porte reversibili

Cod. LUBE

077047Q93

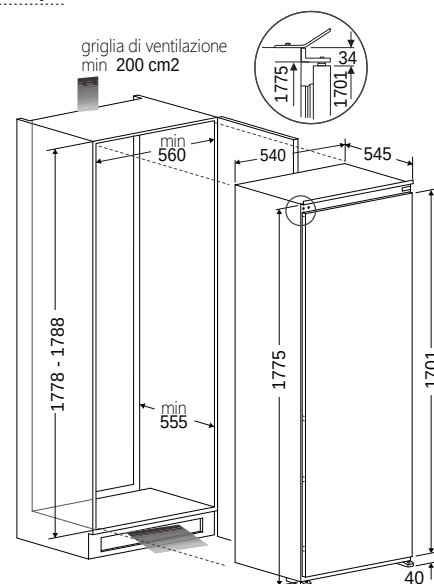

CODICE SAP
7523820035

CODICE EAN
8690842605901

CODICE SAP
7523420031

CODICE EAN
8690842605895



BLSA210M4SN

Frigorifero **monoporta h 121 cm**
statico



Cassetto frutta e
verdura

CARATTERISTICHE PRINCIPALI

- Volume netto totale: 198 L
- Cassetto frutta e verdura
- Controllo meccanico
- Porte reversibili
- Cerniere scorrevoli

Cod. LUBE

077019Q09

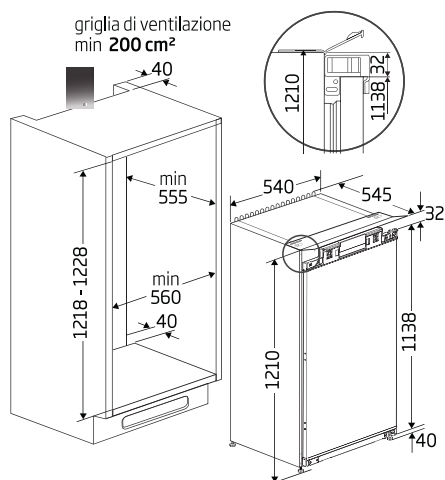

CODICE SAP
7520220026

CODICE EAN
8690842619793

BSSA210K4SN MPS

Frigorifero **congelatore monoporta**
h 121 cm statico



Cassetto frutta e
verdura

CARATTERISTICHE PRINCIPALI

- Volume netto totale: 175 L
- Cassetto frutta e verdura
- Controllo meccanico
- Porte reversibili
- Cerniere scorrevoli
- (volume netto frigorifero: 156 L, volume netto freezer: 19 L)

Cod. LUBE

077019Q11

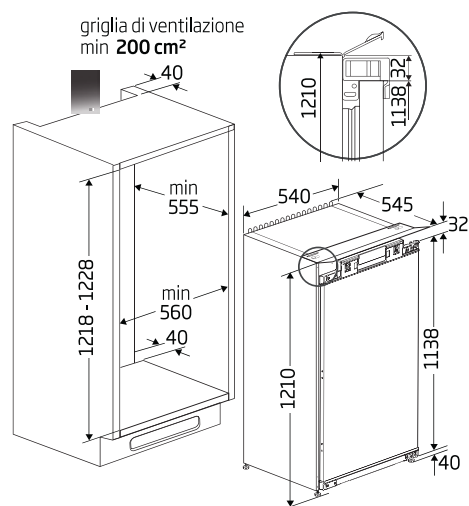

CODICE SAP
7520320025

CODICE EAN
8690842487002

B1804N

Frigorifero **sovrapponibile**
h 87 cm statico



Cassetto frutta e verdura

CARATTERISTICHE PRINCIPALI

- Volume netto totale: 126 L
- Cassetto frutta e verdura
- Controllo meccanico
- Porte reversibili
- Cerniere scorrevoli

Cod. LUBE
077015Q81

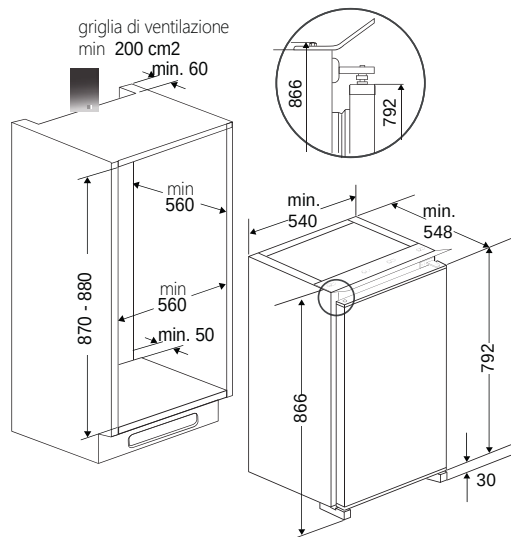

CODICE SAP
7247240510

CODICE EAN
8690842458224

BCR1154HCN

Frigorifero **congelatore sottotavolare**
autoventilato h 82 cm



Sottotavolare

CARATTERISTICHE PRINCIPALI

- Volume netto totale: 107 L
- Cerniere integrate
- (volume netto frigorifero: 92 L, volume netto freezer: 15 L)
- Porte reversibili
- Controllo meccanico

Cod. LUBE
077010Q1D

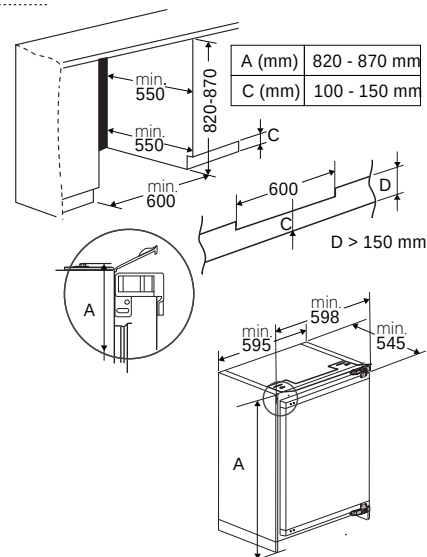

CODICE SAP
7248840512

CODICE EAN
8690842573477

BU1104N

Frigorifero **sottotavolabile**
autoventilato h 82 cm



Sottotavolabile

CARATTERISTICHE PRINCIPALI

- Volume netto totale: 130 L
- Cerniere integrate
- Controllo meccanico
- Porte reversibili

Cod. LUBE
077010Q1A

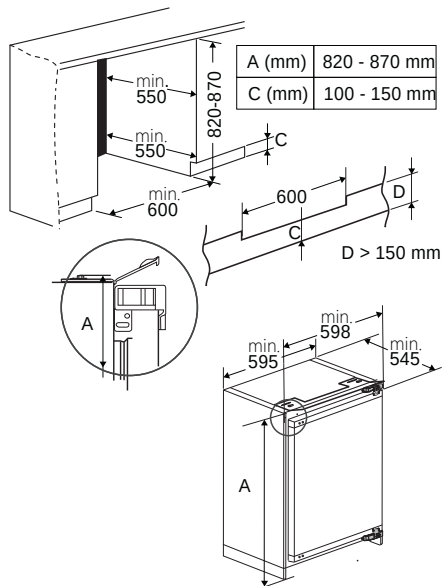

CODICE SAP
7248740516

CODICE EAN
8690842575495

BU1204N
RCRIM17200KSBMPS

Congelatore **sottotavolabile**
autoventilato h 82 cm



Sottotavolabile

CARATTERISTICHE PRINCIPALI

- Volume netto totale: 94 L
- Cerniere integrate
- Controllo meccanico
- Porte reversibili

Cod. LUBE
077070Q07

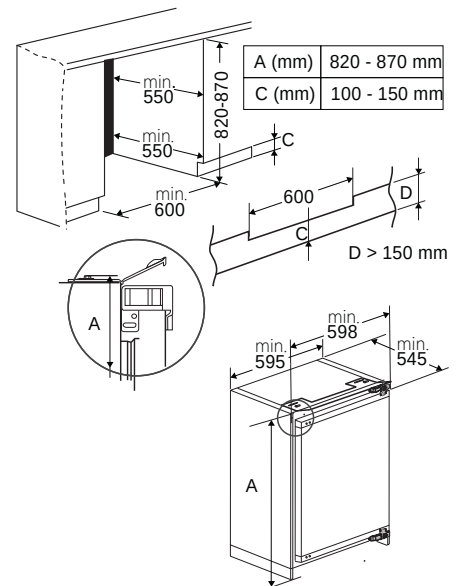

CODICE SAP
7275240514

CODICE EAN
8690842602962



B3RGN6647DYBR
BE3RMAE72107K3EWP5

Frigorifero **Side by Side** con tecnologia **NeoFrost™ Dual Cooling**



Finitura
Dark Inox



Total No Frost



NeoFrost™
Dual Cooling



24H
HarvestFresh®



Comparto
alimenti freschi



Compressore
ProSmart™ Inverter

CARATTERISTICHE PRINCIPALI

- Volume netto totale: 571 L
(volume netto frigorifero: 368L, volume netto freezer: 203 L)
- Display Touch sulla porta
- Water e ice dispenser con **allaccio idrico**
- Macchina del ghiaccio automatica

Cod. LUBE

0 7 7 4 7 0 Q 2 2

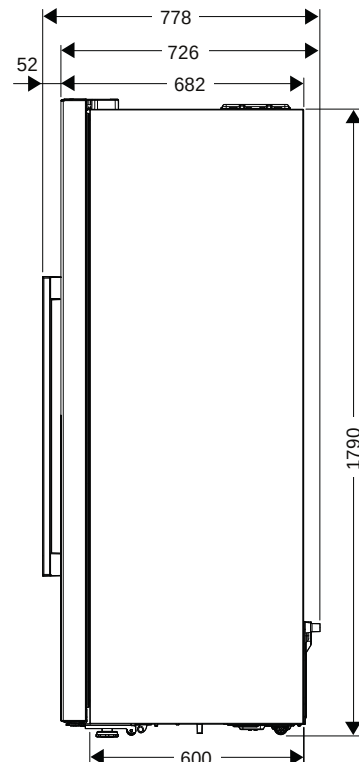
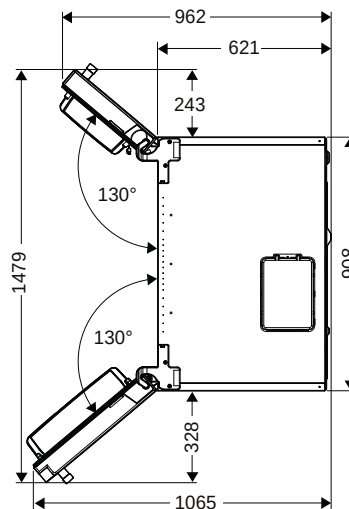
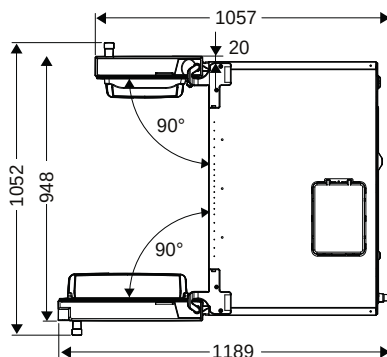

Disponibile da Marzo 2025

CODICE SAP
7292248793

CODICE EAN
8690842598937



B5RCNE565HXBR RCPHMA17200K3BMP5

Frigorifero **combinato** con tecnologia **AeroFlow®**



Finitura
Dark Inox



Total No Frost



AeroFlow®



HarvestFresh®



Compressore
ProSmart™ Inverter

CARATTERISTICHE PRINCIPALI

- Volume netto totale: 490 L
(volume netto frigorifero: 340L, volume netto freezer: 150 L)
- Display elettronico interno
- Cassetto frutta e verdura
- Comparto alimenti freschi
- Porte reversibili

Cod. LUBE

077470Q08

Nb. Beko consiglia che l'operazione di inversione della porta, qualora necessaria, venga effettuata solo da un centro di assistenza autorizzato Beko. Tale intervento sarà a pagamento ed a carico del cliente.

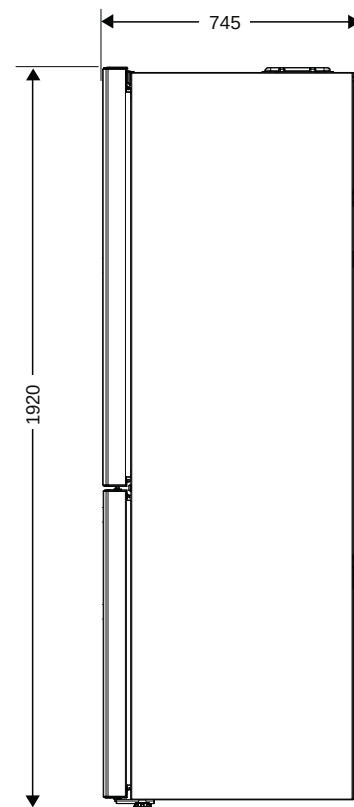
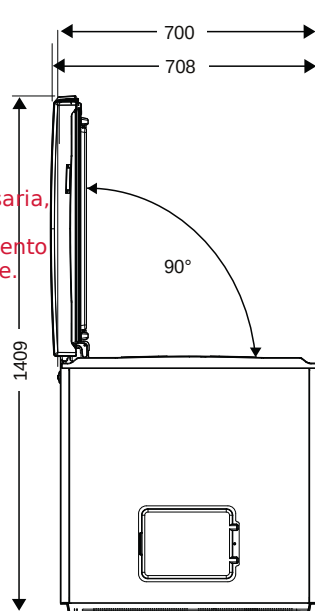

CODICE SAP
7295847602

CODICE EAN
8690842621642

B3RCNE564HXB
BCRIMA/17400KSEMP5

Frigorifero **combinato**
con **tecnologia AeroFlow®**



Finitura
Inox



B3RCNE564HW

Frigorifero **combinato**
con **tecnologia AeroFlow®**



Finitura
Bianca



Total No Frost



Aereoflow®



HarvestFresh®



Comparto alimenti
freschi



Total No Frost



Aereoflow®



HarvestFresh®



Comparto alimenti
freschi

CARATTERISTICHE PRINCIPALI

- Volume netto totale: 490L (volume netto frigorifero: 340 L, volume netto freezer: 150 L)
- Display elettronico interno
- Cassetto frutta e verdura
- Porte reversibili

Cod. LUBE
0 7 7 4 7 0 Q 1 4

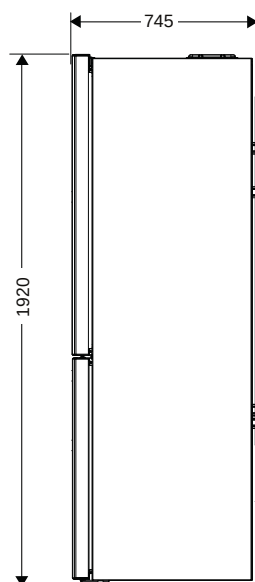
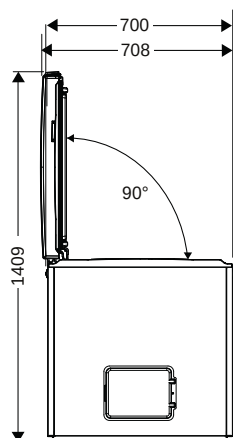

CARATTERISTICHE PRINCIPALI

- Volume netto totale: 490 L (volume netto frigorifero: 340 L, volume netto freezer: 150 L)
- Display elettronico interno
- Cassetto frutta e verdura
- Porte reversibili

Cod. LUBE
0 7 7 4 7 0 Q 1 6

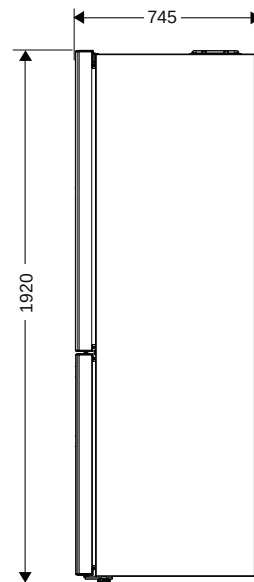
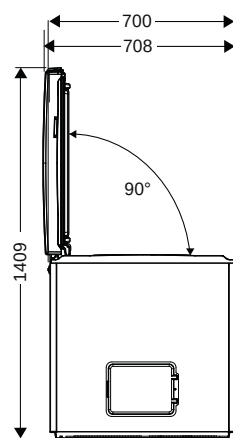

Nb. Beko consiglia che l'operazione di inversione della porta, qualora necessaria, venga effettuata solo da un centro di assistenza autorizzato Beko. Tale intervento sarà a pagamento ed a carico del cliente.

CODICE SAP
7295847603

CODICE EAN
8690842621628

CODICE SAP
7295843701

CODICE EAN
8690842611162

B3RCNA364HYB1
BCBIMAL/400KSPMPS

Frigorifero **combinato**
con **tecnologia AeroFlow®**



Finitura
Inox



B3RCNA364HW

Frigorifero **combinato**
con **tecnologia AeroFlow®**



Finitura
Bianca



Total No Frost



AeroFlow®



24H
HarvestFresh®



Comparto alimenti
freschi



Total No Frost



AeroFlow®



24H
HarvestFresh®

CARATTERISTICHE PRINCIPALI

- Volume netto totale: 316 L (volume netto frigorifero 210 L, volume netto freezer: 106 L)
- Cassetto frutta e verdura
- Display elettronico sulla porta
- Porte reversibili

Cod. LUBE
0 7 7 4 7 0 Q 1 7

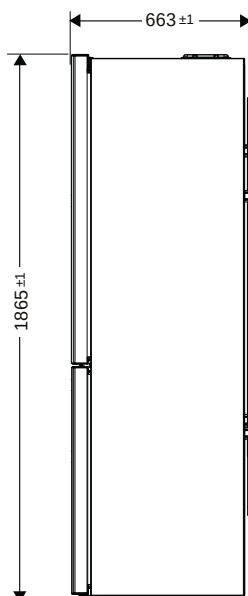
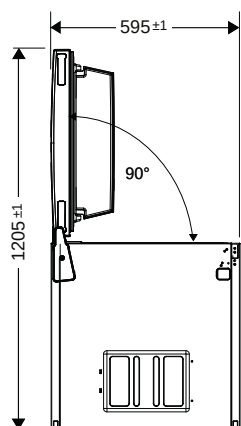

CARATTERISTICHE PRINCIPALI

- Volume netto totale: 316 L (volume netto frigorifero 210 L, volume netto freezer: 106 L)
- Cassetto frutta e verdura
- Display elettronico sulla porta
- Porte reversibili

Cod. LUBE
0 7 7 4 7 0 Q 1 8

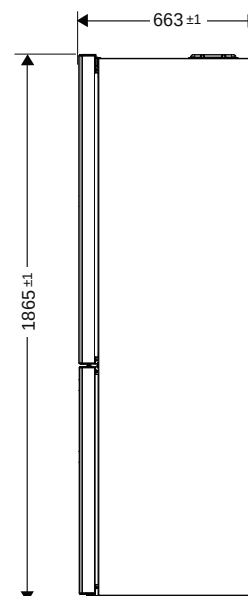
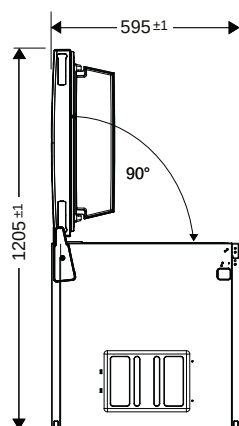

Nb. Beko consiglia che l'operazione di inversione della porta, qualora necessaria, venga effettuata solo da un centro di assistenza autorizzato Beko. Tale intervento sarà a pagamento ed a carico del cliente.

CODICE SAP
7524620016

CODICE EAN
8690842572081

CODICE SAP
7524620003

CODICE EAN
8690842498626

GODITI UNA VITA **PIÙ CONFORTEVOLE.**

Facilità di carico, risparmio energetico, flessibilità di programmazione e tecnologie in grado di massimizzare l'efficacia del lavaggio: trovi tutto questo e molto altro nelle lavatrici da incasso a carica frontale Beko.

Se poi, vuoi dimenticarti completamente del tuo bucato e non doverlo neanche stendere, affidalo alla nostra lavasciuga che ti restituirà capi puliti e asciutti.

Grazie alla tecnologia a vapore SteamCure™, puoi vivere ogni giornata a tutto vapore senza paura di sporcarti. Beko ha la soluzione ottimale per rendere la pulizia dei tuoi vestiti accurata ed efficace, per un bucato senza macchia, antipiega ed igienizzato.



06



**FAI LA SCELTA GIUSTA,
SCEGLI LA FLESSIBILITÀ.**

WITC7612BOW

Lavatrice **completamente integrata**
8 kg



BC41M19736B0HTMPS

Lavasciuga **completamente integrata**
8 kg + 5kg



SteamCure™



Motore ProSmart™ Inverter



EnergySpin



Motore ProSmart™ Inverter

CARATTERISTICHE PRINCIPALI

- Capacità di carico 7 kg
- Display LCD
- Velocità centrifuga 1200 rpm
- 5 programmi di lavaggio
- 5 funzioni ausiliarie: Rapido, Prelavaggio, Antipiega, Pet Hair Removal, Pulizia cestello
- Regolazione partenza ritardata fino a 19 h
- Indicatore tempo rimanente
- Indicatore di fasi del programma
- Selezione della temperatura
- Centrifuga a velocità variabile
- Resistenza Hi-Tech a lunga durata

Cod. LUBE

0 7 7 5 0 5 Q 3 4

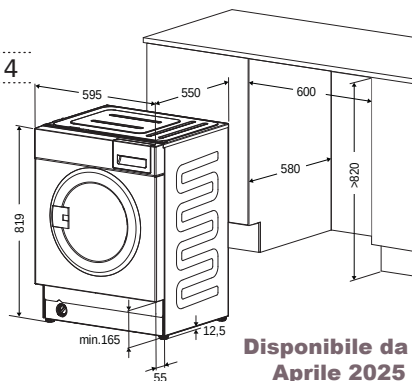

Disponibile da
Aprile 2025

CARATTERISTICHE PRINCIPALI

- Capacità 8kg +5kg
- Display digitale
- Centrifuga 1400 rpm
- 15 programmi
- 3 Funzioni ausiliare: Fast+,Asciugatura, Vapore
- Dimensioni (AxLxP) 84.5x60x57 cm

Cod. LUBE

0 7 7 5 0 5 Q 3 6

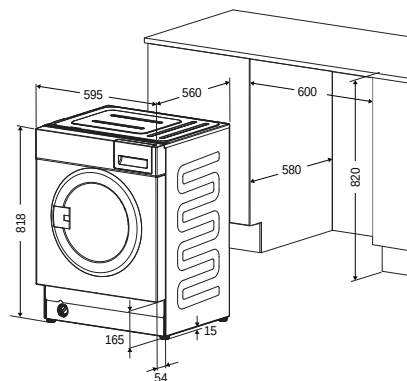

N.b. Inseribile solo in composizioni con modulistica h 72 con piedini h15 utilizzando lo zoccolo di sollevamento, modulistica h 75 con gola e senza zoccolo di sollevamento e modulistica h 84 versione Bridge, senza zoccolo di sollevamento.

CODICE SAP 7177581200	CODICE EAN 8690842395208
---------------------------------	------------------------------------

CODICE SAP 7162546100	CODICE EAN 8690842467653
---------------------------------	------------------------------------

